

具有中断输出和配置寄存器的 TCA9555 低电压 16 位 I²C 和 SMBus I/O 扩展器

1 特性

- 低待机电流消耗，最大为 3.5 μ A
- I²C 至并行端口扩展器
- 开漏电路低电平有效中断输出
- 可耐受 5V 电压的 I/O 端口
- 兼容大多数微控制器
- 400kHz 快速 I²C 总线
- 具有 3 个地址引脚的可配置从器件地址
- 极性反转寄存器
- 具有最大高电流驱动能力的锁存输出，可用于直接驱动 LED
- 锁断性能超过 100mA，符合 JESD 78 II 类规范
- 静电放电 (ESD) 保护性能超过 JESD 22 规范的要求
 - 2000V 人体模型 (A114-A)
 - 1000V 充电器件模型 (C101)

2 应用

- 服务器
- 路由器（电信交换设备）
- 个人计算机
- 个人电子产品

- 工业自动化设备
- 采用 GPIO 受限处理器的产品

3 说明

该面向两线双向总线 (I²C) 的 16 位 I/O 扩展器专为 1.65V 至 5.5V V_{CC} 工作电压而设计。它可通过 I²C 接口为大多数微控制器系列产品提供通用远程 I/O 扩展。

TCA9555 由两个 8 位配置（输入或输出选择）、输入端口、输出端口和极性反转（高电平有效或低电平有效运行）寄存器组成。在加电时，I/O 被配置为输入。系统主控制器可以通过写入 I/O 配置位将 I/O 启动为输入或输出。每一个输入或者输出的数据被保存在相应的输入或者输出寄存器内。输入端口寄存器的极性可借助极性反转寄存器进行转换。

器件信息⁽¹⁾

器件型号	封装	封装尺寸（标称值）
TCA9555	TSSOP (24) PW	7.80mm x 4.40mm
	SSOP (24) DB	8.20mm x 5.30mm
	WQFN (24) RTW	4.00mm x 4.00mm
	VQFN (24) RGE	4.00mm x 4.00mm

(1) 如需了解所有可用封装，请参阅数据表末尾的可订购产品附录。

简化原理图

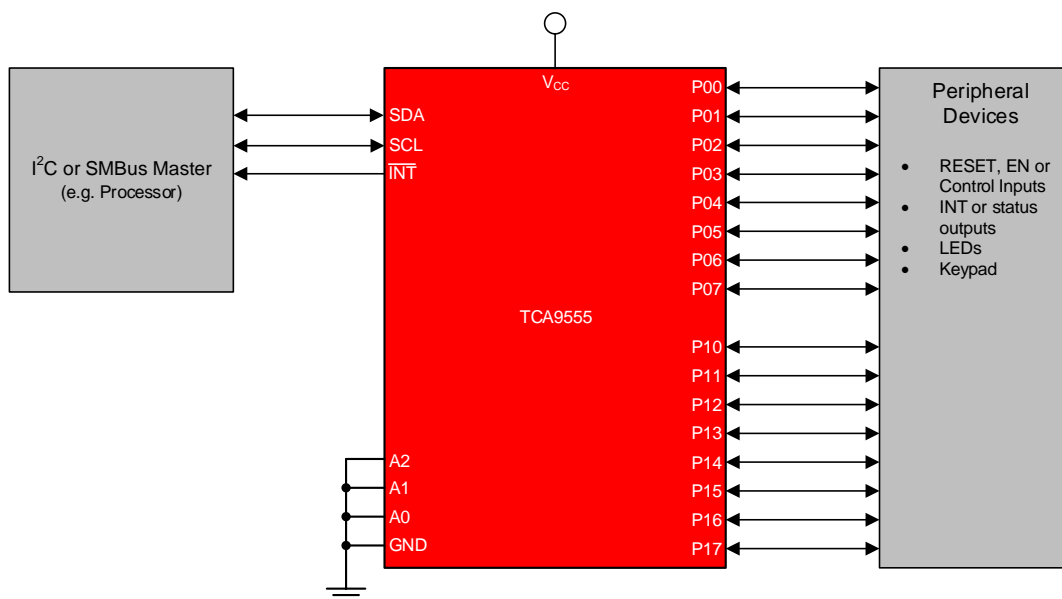

目录

1 特性	1	9.3 Feature Description	15
2 应用	1	9.4 Device Functional Modes	16
3 说明	1	9.5 Programming	16
4 修订历史记录	2	9.6 Register Maps	24
5 说明 (续)	3	10 Application and Implementation	25
6 Pin Configuration and Functions	4	10.1 Application Information	25
7 Specifications	5	10.2 Typical Application	25
7.1 Absolute Maximum Ratings	5	11 Power Supply Recommendations	29
7.2 ESD Ratings	5	12 Layout	31
7.3 Recommended Operating Conditions	5	12.1 Layout Guidelines	31
7.4 Thermal Information	6	12.2 Layout Example	31
7.5 Electrical Characteristics	6	13 器件和文档支持	32
7.6 I ² C Interface Timing Requirements	7	13.1 文档支持	32
7.7 Switching Characteristics	8	13.2 接收文档更新通知	32
7.8 Typical Characteristics	9	13.3 社区资源	32
8 Parameter Measurement Information	12	13.4 商标	32
9 Detailed Description	15	13.5 静电放电警告	32
9.1 Overview	15	13.6 术语表	32
9.2 Functional Block Diagram	15	14 机械、封装和可订购信息	32

4 修订历史记录

注：之前版本的页码可能与当前版本有所不同。

Changes from Revision D (July 2016) to Revision E	Page
• 更改了器件信息表	1
• Changed the Pin Configuration images	4

Changes from Revision C (June 2016) to Revision D	Page
• 已添加 向器件信息表中添加了 DB 封装	1

Changes from Revision A (July 2009) to Revision B	Page
• 已添加 添加了引脚配置和功能部分、ESD 额定值表、特性说明部分、器件功能模式、应用和实施部分、电源建议部分、布局部分、器件和文档支持部分以及机械、封装和可订购信息部分	1

Changes from Revision B (July 2015) to Revision C	Page
• 已添加 向器件信息表中添加了 RGE 封装	1
• Changed V _{IH} for I ² C pins limited to V _{CC} , with note allowing higher voltage	5
• Added I _{OL} for different T _j	5
• Removed ΔI _{CC} spec from the <i>Electrical Characteristics</i> table, added ΔI _{CC} typical characteristics graph	6
• Changed I _{CC} standby into different input states	7
• Changed C _{io} maximum	7
• Changed Typical characteristic plots with updated data	9
• POR requirements, bounded lowest voltage allowed during glitch	30

5 说明（续）

除了包含内部 I/O 上拉电阻器之外，TCA9555 与 TCA9535 相同，该电阻器在配置为输入和未驱动时，可将 I/O 拉至默认高电平。

三个硬件引脚（A0、A1 和 A2）用于对 I²C 地址进行编程，该地址允许高达八个 TCA9555 器件共享同一个 I²C 总线或 SMBus。TCA9555 的固定 I²C 地址与 PCF8575、PCF8575C 和 PCF8574 相同，最多允许这些器件中任意八个共享同一个 I²C 总线或 SMBus。

6 Pin Configuration and Functions

**DB, PW Package
24-Pin TSSOP
Top View**

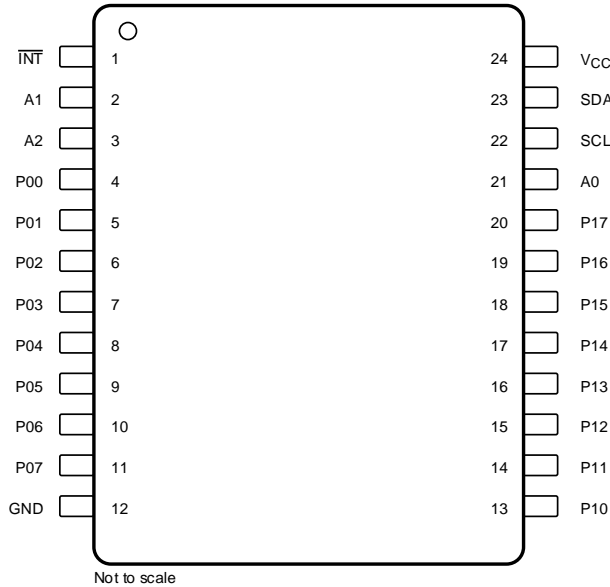

**RTW, RGE Package
24-Pin WQFN, VQFN with Exposed Thermal Pad
Top View**

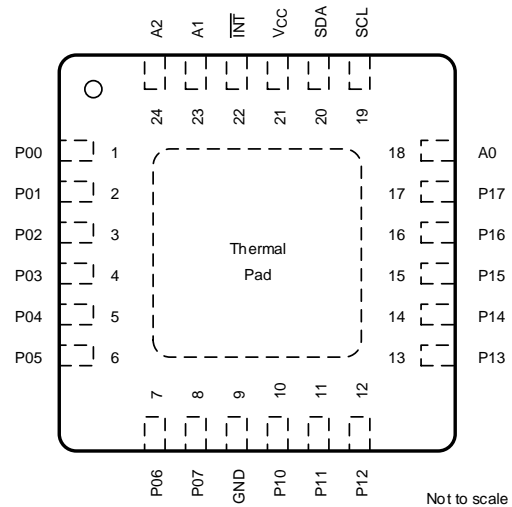

The exposed thermal pad, if used, must be connected as a secondary ground or left electrically open.

Pin Functions

NAME	PIN NO.		TYPE	DESCRIPTION
	DB, PW	RTW, RGE		
A0	21	18	Input	Address input 0. Connect directly to V _{CC} or ground
A1	2	23	Input	Address input 1. Connect directly to V _{CC} or ground
A2	3	24	Input	Address input 2. Connect directly to V _{CC} or ground
GND	12	9	GND	Ground
INT	1	22	Output	Interrupt output. Connect to V _{CC} through a pull-up resistor
P00	4	1	I/O	P-port I/O. Push-pull design structure. At power on, P00 is configured as an input
P01	5	2	I/O	P-port I/O. Push-pull design structure. At power on, P01 is configured as an input
P02	6	3	I/O	P-port I/O. Push-pull design structure. At power on, P02 is configured as an input
P03	7	4	I/O	P-port I/O. Push-pull design structure. At power on, P03 is configured as an input
P04	8	5	I/O	P-port I/O. Push-pull design structure. At power on, P04 is configured as an input
P05	9	6	I/O	P-port I/O. Push-pull design structure. At power on, P05 is configured as an input
P06	10	7	I/O	P-port I/O. Push-pull design structure. At power on, P06 is configured as an input
P07	11	8	I/O	P-port I/O. Push-pull design structure. At power on, P07 is configured as an input
P10	13	10	I/O	P-port I/O. Push-pull design structure. At power on, P10 is configured as an input
P11	14	11	I/O	P-port I/O. Push-pull design structure. At power on, P11 is configured as an input
P12	15	12	I/O	P-port I/O. Push-pull design structure. At power on, P12 is configured as an input
P13	16	13	I/O	P-port I/O. Push-pull design structure. At power on, P13 is configured as an input
P14	17	14	I/O	P-port I/O. Push-pull design structure. At power on, P14 is configured as an input
P15	18	15	I/O	P-port I/O. Push-pull design structure. At power on, P15 is configured as an input
P16	19	16	I/O	P-port I/O. Push-pull design structure. At power on, P16 is configured as an input
P17	20	17	I/O	P-port I/O. Push-pull design structure. At power on, P17 is configured as an input
SCL	22	19	Input	Serial clock bus. Connect to V _{CC} through a pull-up resistor
SDA	23	20	Input	Serial data bus. Connect to V _{CC} through a pull-up resistor
V _{CC}	24	21	Supply	Supply voltage

7 Specifications

7.1 Absolute Maximum Ratings

over operating free-air temperature range (unless otherwise noted)⁽¹⁾

		MIN	MAX	UNIT
V _{CC}	Supply voltage	-0.5	6	V
V _I	Input voltage ⁽²⁾	-0.5	6	V
V _O	Output voltage ⁽²⁾	-0.5	6	V
I _{IK}	Input clamp current	V _I < 0	-20	mA
I _{OK}	Output clamp current	V _O < 0	-20	mA
I _{I_{OK}}	Input-output clamp current	V _O < 0 or V _O > V _{CC}	±20	mA
I _{OL}	Continuous output low current	V _O = 0 to V _{CC}	50	mA
I _{OH}	Continuous output high current	V _O = 0 to V _{CC}	-50	mA
I _{CC}	Continuous current through GND		-250	mA
	Continuous current through V _{CC}		160	
T _{j(MAX)}	Maximum junction temperature		100	°C
T _{stg}	Storage temperature	-65	150	°C

- (1) Stresses beyond those listed under *Absolute Maximum Ratings* may cause permanent damage to the device. These are stress ratings only, which do not imply functional operation of the device at these or any other conditions beyond those indicated under *Recommended Operating Conditions*. Exposure to absolute-maximum-rated conditions for extended periods may affect device reliability.
- (2) The input negative-voltage and output voltage ratings may be exceeded if the input and output current ratings are observed.

7.2 ESD Ratings

		VALUE	UNIT
V _(ESD)	Electrostatic discharge	Human body model (HBM), per ANSI/ESDA/JEDEC JS-001 ⁽¹⁾	±2000
		Charged-device model (CDM), per JEDEC specification JESD22-C101 or ANSI/ESDA/JEDEC JS-002 ⁽²⁾	±1000

- (1) JEDEC document JEP155 states that 500-V HBM allows safe manufacturing with a standard ESD control process.
- (2) JEDEC document JEP157 states that 250-V CDM allows safe manufacturing with a standard ESD control process.

7.3 Recommended Operating Conditions

		MIN	MAX	UNIT
V _{CC}	Supply voltage	1.65	5.5	V
V _{IH}	High-level input voltage	SCL, SDA	0.7 × V _{CC}	V _{CC} ⁽¹⁾
		A2–A0, P07–P00, P17–P10	0.7 × V _{CC}	5.5
V _{IL}	Low-level input voltage	SCL, SDA	-0.5	0.3 × V _{CC}
		A2–A0, P07–P00, P17–P10	-0.5	0.3 × V _{CC}
I _{OH}	High-level output current	P07–P00, P17–P10	-10	mA
I _{OL}	Low-level output current ⁽²⁾	P07–P00, P17–P10	T _j ≤ 65°C	25
			T _j ≤ 85°C	18
			T _j ≤ 100°C	11
I _{OL}	Low-level output current ⁽²⁾	$\overline{\text{INT}}$, SDA	T _j ≤ 85°C	6
			T _j ≤ 100°C	3.5
T _A	Operating free-air temperature	-40	85	°C

- (1) For voltages applied above V_{CC}, an increase in I_{CC} results.
- (2) The values shown apply to specific junction temperatures, which depend on the R_{θJA} of the package used. See the [Calculating Junction Temperature and Power Dissipation](#) section on how to calculate the junction temperature.

7.4 Thermal Information

THERMAL METRIC ⁽¹⁾	TCA9555				UNIT
	PW (TSSOP)	DB (SSOP)	RTW (WQFN)	RGE (VQFN)	
	24 PINS	24 PINS	24 PINS	24 PINS	
R _{θJA} Junction-to-ambient thermal resistance	108.8	92.9	43.6	48.4	°C/W
R _{θJC(top)} Junction-to-case (top) thermal resistance	54	53.5	46.2	58.1	°C/W
R _{θJB} Junction-to-board thermal resistance	62.8	50.4	22.1	27.1	°C/W
Ψ _{JT} Junction-to-top characterization parameter	11.1	21.9	1.5	3.3	°C/W
Ψ _{JB} Junction-to-board characterization parameter	62.3	50.1	22.2	27.2	°C/W
R _{θJC(bot)} Junction-to-case (bottom) thermal resistance	N/A	N/A	10.7	15.3	°C/W

(1) For more information about traditional and new thermal metrics, see the [Semiconductor and IC Package Thermal Metrics](#) application report.

7.5 Electrical Characteristics

over recommended operating free-air temperature range (unless otherwise noted)

PARAMETER	TEST CONDITIONS	V _{CC}	MIN	TYP ⁽¹⁾	MAX	UNIT
V _{IK} Input diode clamp voltage	I _I = -18 mA	1.65 V to 5.5 V	-1.2			V
V _{PORR} Power-on reset voltage, V _{CC} rising	V _I = V _{CC} or GND, I _O = 0	1.65 V to 5.5 V		1.2	1.5	V
V _{PORF} Power-on reset voltage, V _{CC} falling	V _I = V _{CC} or GND, I _O = 0	1.65 V to 5.5 V	0.75	1		V
V _{OH} P-port high-level output voltage ⁽²⁾	I _{OH} = -8 mA	1.65 V	1.2			V
		2.3 V	1.8			
		3 V	2.6			
		4.75 V	4.1			
	I _{OH} = -10 mA	1.65 V	1			
		2.3 V	1.7			
		3 V	2.5			
		4.75 V	4			
I _{OL} Low-level output current	SDA	V _{OL} = 0.4 V	1.65 V to 5.5 V	3		mA
	P port ⁽³⁾	V _{OL} = 0.5 V	1.65 V to 5.5 V	8		mA
		V _{OL} = 0.7 V	1.65 V to 5.5 V	10		mA
	$\overline{\text{INT}}$	V _{OL} = 0.4 V	1.65 V to 5.5 V	3		mA
I _I Input leakage current	SCL, SDA Input leakage	V _I = V _{CC} or GND	1.65 V to 5.5 V		±1	μA
	A2–A0 Input leakage	V _I = V _{CC} or GND	1.65 V to 5.5 V		±1	μA
I _{IH} Input high leakage current	P port	V _I = V _{CC}	1.65 V to 5.5 V		1	μA
I _{IL} Input low leakage current	P port	V _I = GND	1.65 V to 5.5 V		-100	μA

(1) All typical values are at nominal supply voltage (1.8-, 2.5-, 3.3-, or 5-V V_{CC}) and T_A = 25°C.

(2) Each I/O must be externally limited to a maximum of 25 mA, and each octal (P07–P00 and P17–P10) must be limited to a maximum current of 100 mA, for a device total of 200 mA.

(3) The total current sourced by all I/Os must be limited to 160 mA (80 mA for P07–P00 and 80 mA for P17–P10).

Electrical Characteristics (continued)

over recommended operating free-air temperature range (unless otherwise noted)

PARAMETER		TEST CONDITIONS		V _{CC}	MIN	TYP ⁽¹⁾	MAX	UNIT	
I _{CC}	Quiescent current	Operating mode	I _O = 0, I/O = inputs, f _{SCL} = 400 kHz, t _r = 3 ns, No load	5.5 V		22	40	μA	
				3.6 V		11	30		
				2.7 V		8	19		
				1.95 V		5	11		
	Quiescent current	Standby mode	Low inputs	V _I = GND, I _O = 0, I/O = inputs, f _{SCL} = 0 kHz, No load	5.5 V		1.1	1.5	mA
					3.6 V		0.7	1.3	
					2.7 V		0.5	1	
					1.95 V		0.3	0.9	
		Standby mode	High inputs	V _I = V _{CC} , I _O = 0, I/O = inputs, f _{SCL} = 0 kHz, No load	5.5 V		2.5	3.5	μA
					3.6 V		1	1.8	
					2.7 V		0.7	1.6	
					1.95 V		0.5	1	
C _I	Input capacitance	SCL	V _I = V _{CC} or GND	1.65 V to 5.5 V		3	8	pF	
C _{io}	Input-output pin capacitance	SDA	V _{IO} = V _{CC} or GND	1.65 V to 5.5 V		3	9.5	pF	
		P port				3.7	9.5		

7.6 I²C Interface Timing Requirements

over recommended operating free-air temperature range (unless otherwise noted) (see Figure 19)

				MIN	MAX	UNIT
I²C BUS—STANDARD MODE						
f _{scl}	I ² C clock frequency			0	100	kHz
t _{sch}	I ² C clock high time			4		μs
t _{scl}	I ² C clock low time			4.7		μs
t _{sp}	I ² C spike time				50	ns
t _{sds}	I ² C serial-data setup time			250		ns
t _{sdh}	I ² C serial-data hold time			0		ns
t _{icr}	I ² C input rise time				1000	ns
t _{icf}	I ² C input fall time				300	ns
t _{ocf}	I ² C output fall time		10-pF to 400-pF bus		300	ns
t _{buf}	I ² C bus free time between stop and start			4.7		μs
t _{sts}	I ² C start or repeated start condition setup			4.7		μs
t _{sth}	I ² C start or repeated start condition hold			4		μs
t _{sps}	I ² C stop condition setup			4		μs
t _{vd(data)}	Valid data time		SCL low to SDA output valid		3.45	μs
t _{vd(ack)}	Valid data time of ACK condition		ACK signal from SCL low to SDA (out) low		3.45	μs
C _b	I ² C bus capacitive load				400	pF
I²C BUS—FAST MODE						
f _{scl}	I ² C clock frequency			0	400	kHz
t _{sch}	I ² C clock high time			0.6		μs
t _{scl}	I ² C clock low time			1.3		μs
t _{sp}	I ² C spike time				50	ns
t _{sds}	I ² C serial-data setup time			100		ns
t _{sdh}	I ² C serial-data hold time			0		ns
t _{icr}	I ² C input rise time			20	300	ns

I²C Interface Timing Requirements (continued)

 over recommended operating free-air temperature range (unless otherwise noted) (see [Figure 19](#))

		MIN	MAX	UNIT
t _{icf}	I ² C input fall time	20 × (V _{CC} / 5.5 V)	300	ns
t _{ocf}	I ² C output fall time	10-pF to 400-pF bus	20 × (V _{CC} / 5.5 V)	300
t _{buf}	I ² C bus free time between stop and start	1.3		μs
t _{sts}	I ² C start or repeated start condition setup	0.6		μs
t _{sth}	I ² C start or repeated start condition hold	0.6		μs
t _{sps}	I ² C stop condition setup	0.6		μs
t _{vd(data)}	Valid data time	SCL low to SDA output valid	0.9	μs
t _{vd(ack)}	Valid data time of ACK condition	ACK signal from SCL low to SDA (out) low	0.9	μs
C _b	I ² C bus capacitive load		400	pF

7.7 Switching Characteristics

 over recommended operating free-air temperature range, C_L ≤ 100 pF (unless otherwise noted) (see [Figure 20](#) and [Figure 21](#))

PARAMETER		FROM (INPUT)	TO (OUTPUT)	MIN	MAX	UNIT
t _{iv}	Interrupt valid time	P port	$\overline{\text{INT}}$		4	μs
t _{ir}	Interrupt reset delay time	SCL	$\overline{\text{INT}}$		4	μs
t _{pv}	Output data valid; For V _{CC} = 2.3 V–5.5 V	SCL	P port		200	ns
	Output data valid; For V _{CC} = 1.65 V–2.3 V				300	ns
t _{ps}	Input data setup time	P port	SCL	150		ns
t _{ph}	Input data hold time	P port	SCL	1		μs

7.8 Typical Characteristics

T_A = 25°C (unless otherwise noted)

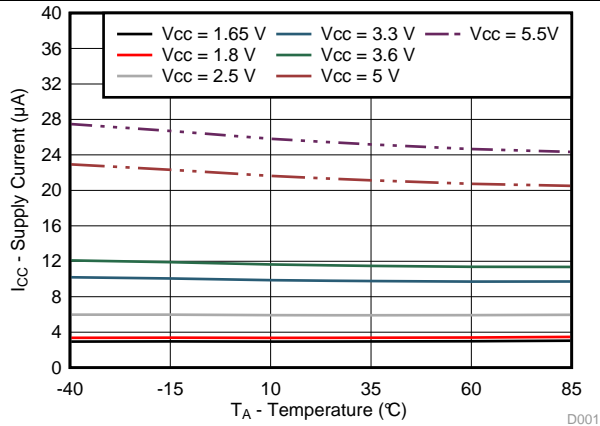

Figure 1. Supply Current vs Temperature for Different Supply Voltage (V_{CC})

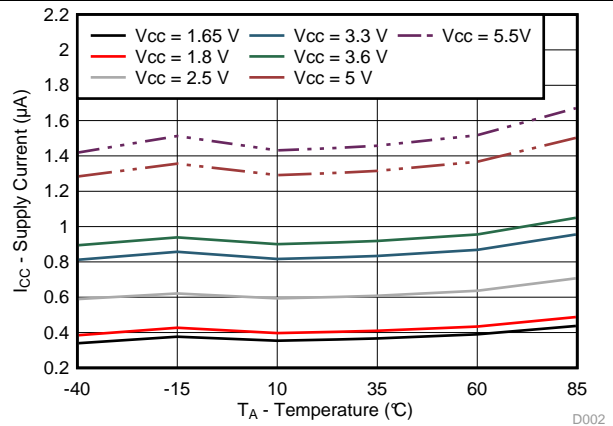

Figure 2. Standby Supply Current vs Temperature for Different Supply Voltage (V_{CC})

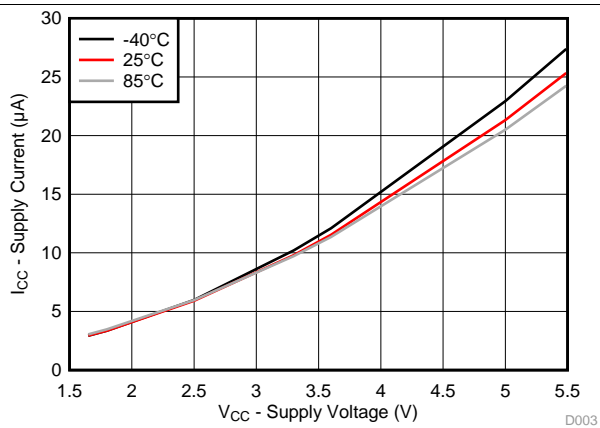

Figure 3. Supply Current vs Supply Voltage for Different Temperature (T_A)

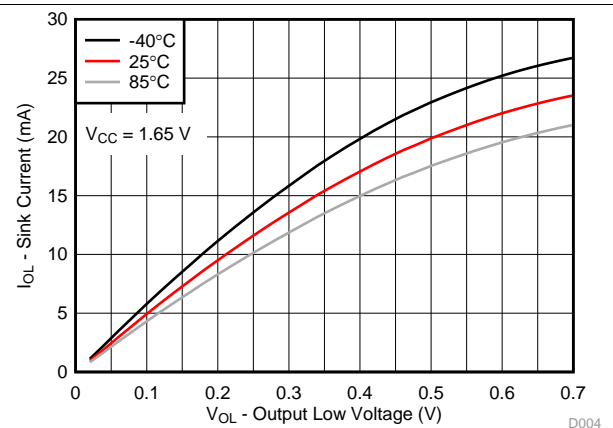

Figure 4. I/O Sink Current vs Output Low Voltage for Different Temperature (T_A) for V_{CC} = 1.65 V

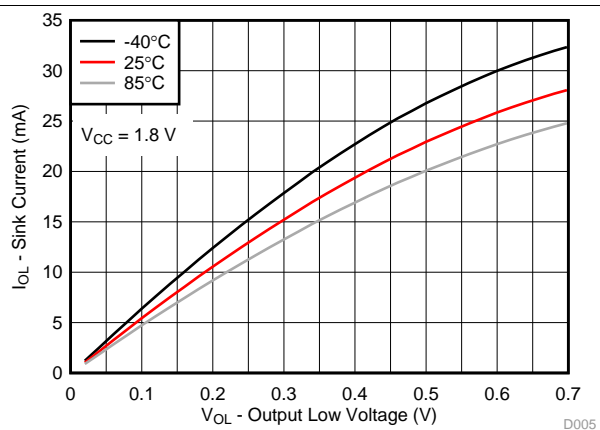

Figure 5. I/O Sink Current vs Output Low Voltage for Different Temperature (T_A) for V_{CC} = 1.8 V

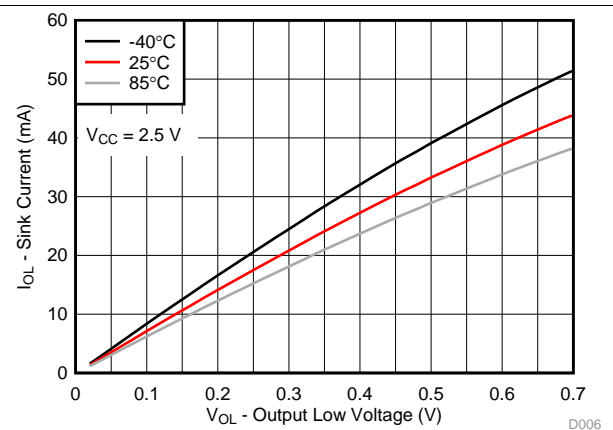

Figure 6. I/O Sink Current vs Output Low Voltage for Different Temperature (T_A) for V_{CC} = 2.5 V

Typical Characteristics (continued)

$T_A = 25^\circ\text{C}$ (unless otherwise noted)

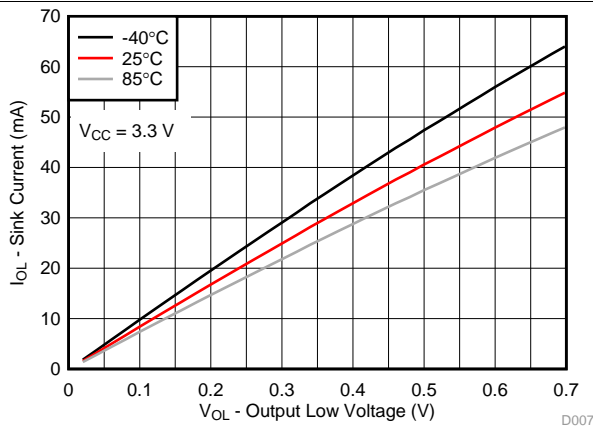

Figure 7. I/O Sink Current vs Output Low Voltage for Different Temperature (T_A) for $V_{CC} = 3.3\text{ V}$

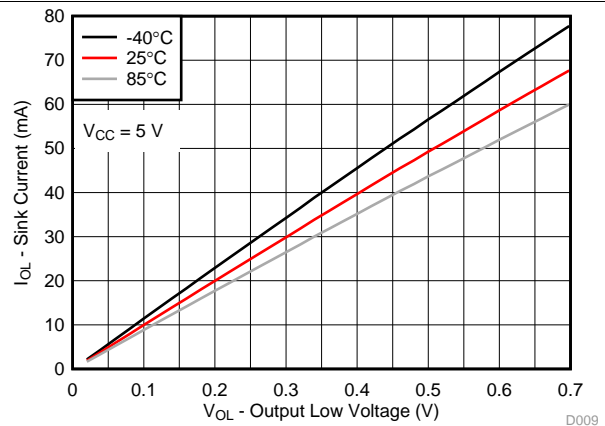

Figure 8. I/O Sink Current vs Output Low Voltage for Different Temperature (T_A) for $V_{CC} = 5\text{ V}$

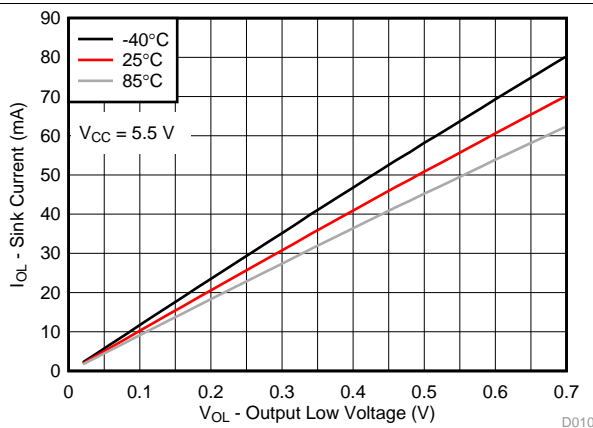

Figure 9. I/O Sink Current vs Output Low Voltage for Different Temperature (T_A) for $V_{CC} = 5.5\text{ V}$

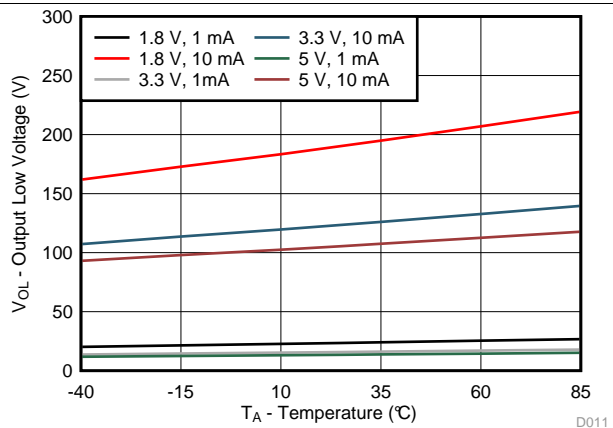

Figure 10. I/O Low Voltage vs Temperature for Different V_{CC} and I_{OL}

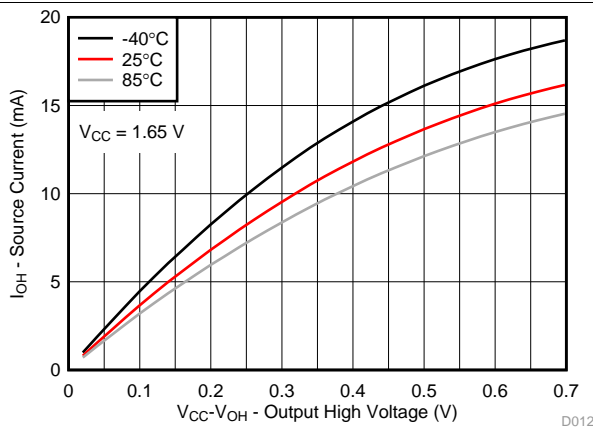

Figure 11. I/O Source Current vs Output High Voltage for Different Temperature (T_A) for $V_{CC} = 1.65\text{ V}$

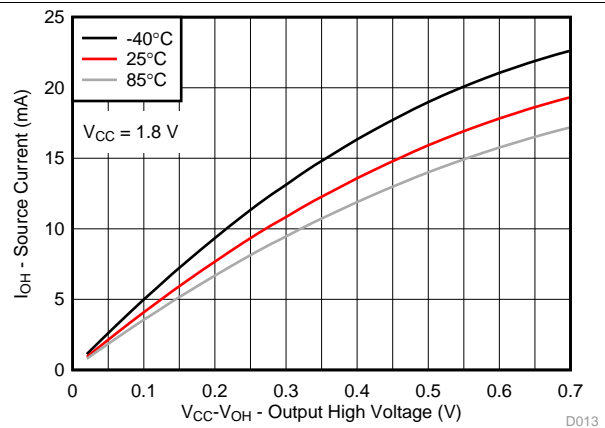

Figure 12. I/O Source Current vs Output High Voltage for Different Temperature (T_A) for $V_{CC} = 1.8\text{ V}$

Typical Characteristics (continued)

T_A = 25°C (unless otherwise noted)

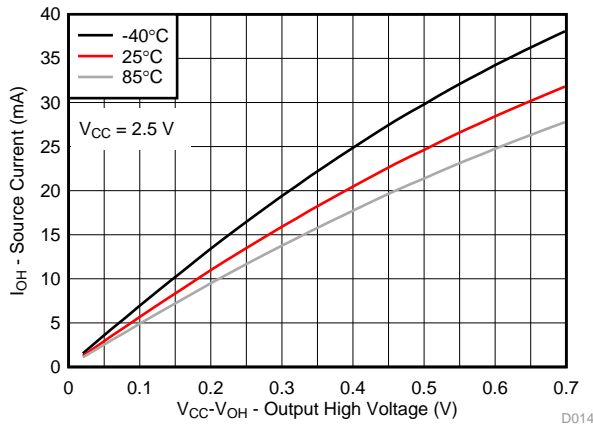

Figure 13. I/O Source Current vs Output High Voltage for Different Temperature (T_A) for V_{CC} = 2.5 V

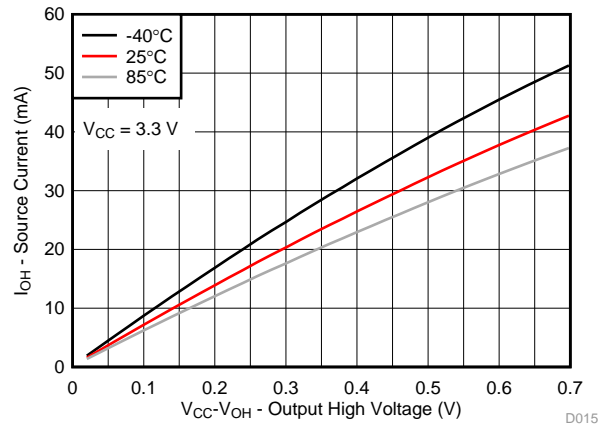

Figure 14. I/O Source Current vs Output High Voltage for Different Temperature (T_A) for V_{CC} = 3.3 V

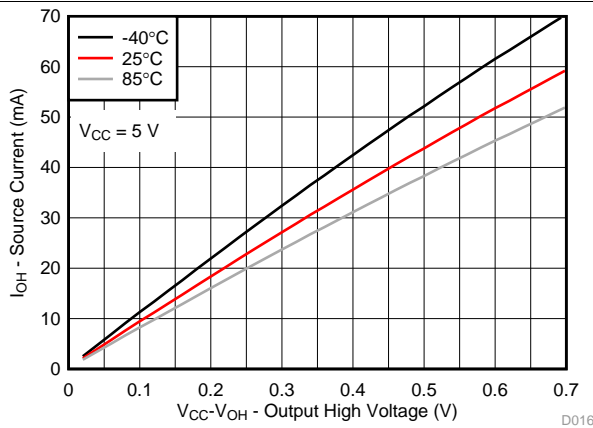

Figure 15. I/O Source Current vs Output High Voltage for Different Temperature (T_A) for V_{CC} = 5 V

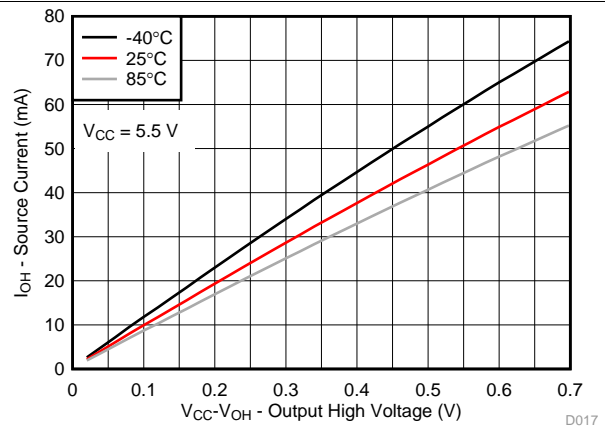

Figure 16. I/O Source Current vs Output High Voltage for Different Temperature (T_A) for V_{CC} = 5.5 V

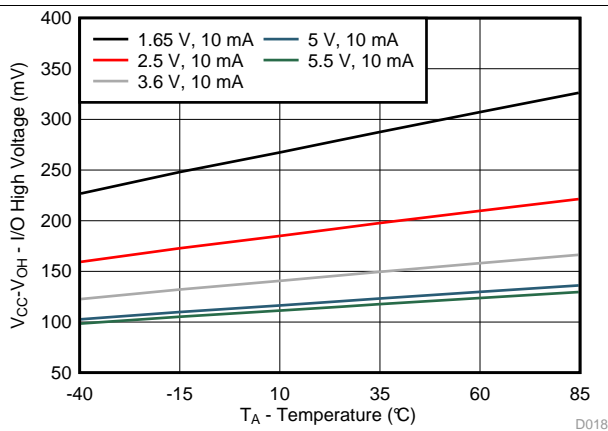

Figure 17. V_{CC} – V_{OH} Voltage vs Temperature for Different V_{CC}

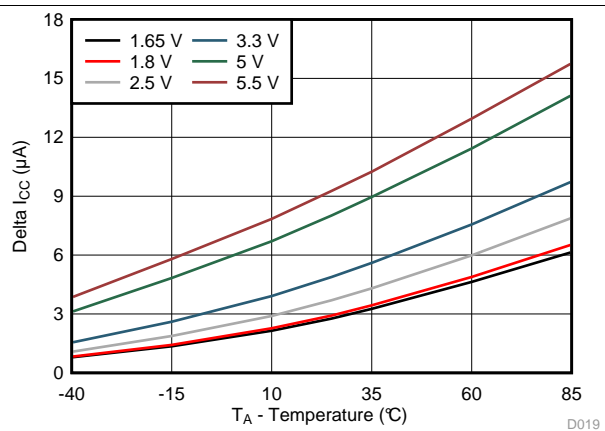
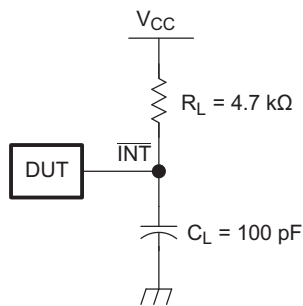
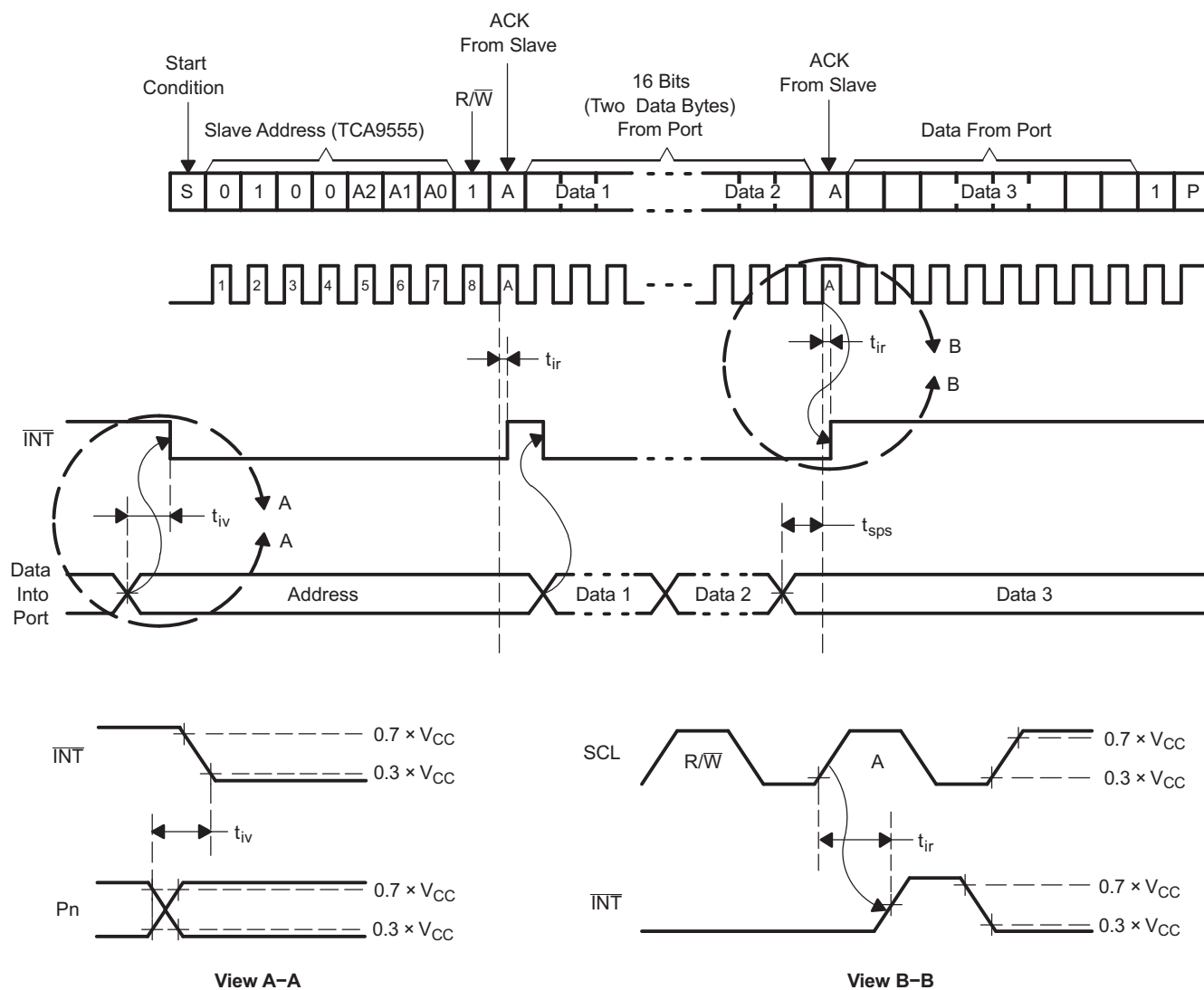

Figure 18. Δ I_{CC} vs Temperature for Different V_{CC} (V_I = V_{CC} – 0.6 V)

Parameter Measurement Information (continued)



INTERRUPT LOAD CONFIGURATION



- A. C_L includes probe and jig capacitance.
- B. All inputs are supplied by generators having the following characteristics: $PRR \leq 10$ MHz, $Z_O = 50 \Omega$, $t_r/t_f \leq 30$ ns.
- C. All parameters and waveforms are not applicable to all devices.

Figure 20. Interrupt Load Circuit and Voltage Waveforms

Parameter Measurement Information (continued)

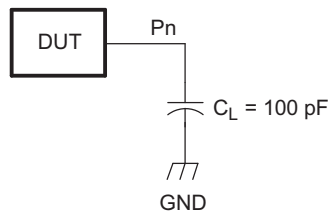

P-PORT LOAD CONFIGURATION

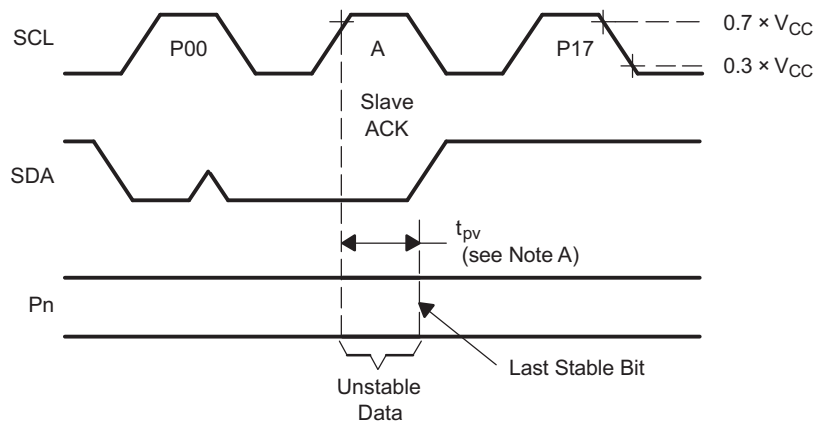

WRITE MODE ($R/\bar{W} = 0$)

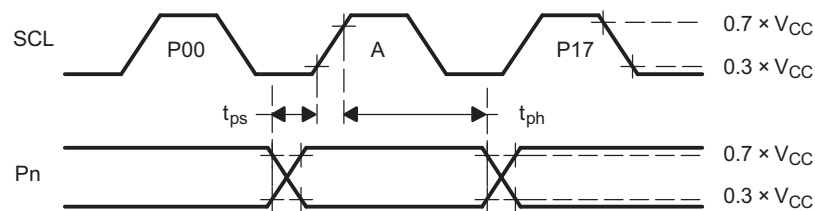

READ MODE ($R/\bar{W} = 1$)

- A. C_L includes probe and jig capacitance.
- B. t_{pv} is measured from $0.7 \times V_{CC}$ on SCL to 50% I/O (P_n) output.
- C. All inputs are supplied by generators having the following characteristics: $PRR \leq 10$ MHz, $Z_O = 50 \Omega$, $t_r/t_f \leq 30$ ns.
- D. The outputs are measured one at a time, with one transition per measurement.
- E. All parameters and waveforms are not applicable to all devices.

Figure 21. P-Port Load Circuit and Voltage Waveforms

9 Detailed Description

9.1 Overview

The TCA9555 is a 16-bit I/O expander for the two-line bidirectional bus (I²C) is designed for 1.65-V to 5.5-V V_{CC} operation. It provides general-purpose remote I/O expansion for most microcontroller families via the I²C interface.

One of the features of the TCA9555, is that the $\overline{\text{INT}}$ output can be connected to the interrupt input of a microcontroller. By sending an interrupt signal on this line, the remote I/O can inform the microcontroller if there is incoming data on its ports without having to communicate via the I²C bus. Thus, the TCA9555 can remain a simple slave device.

9.2 Functional Block Diagram

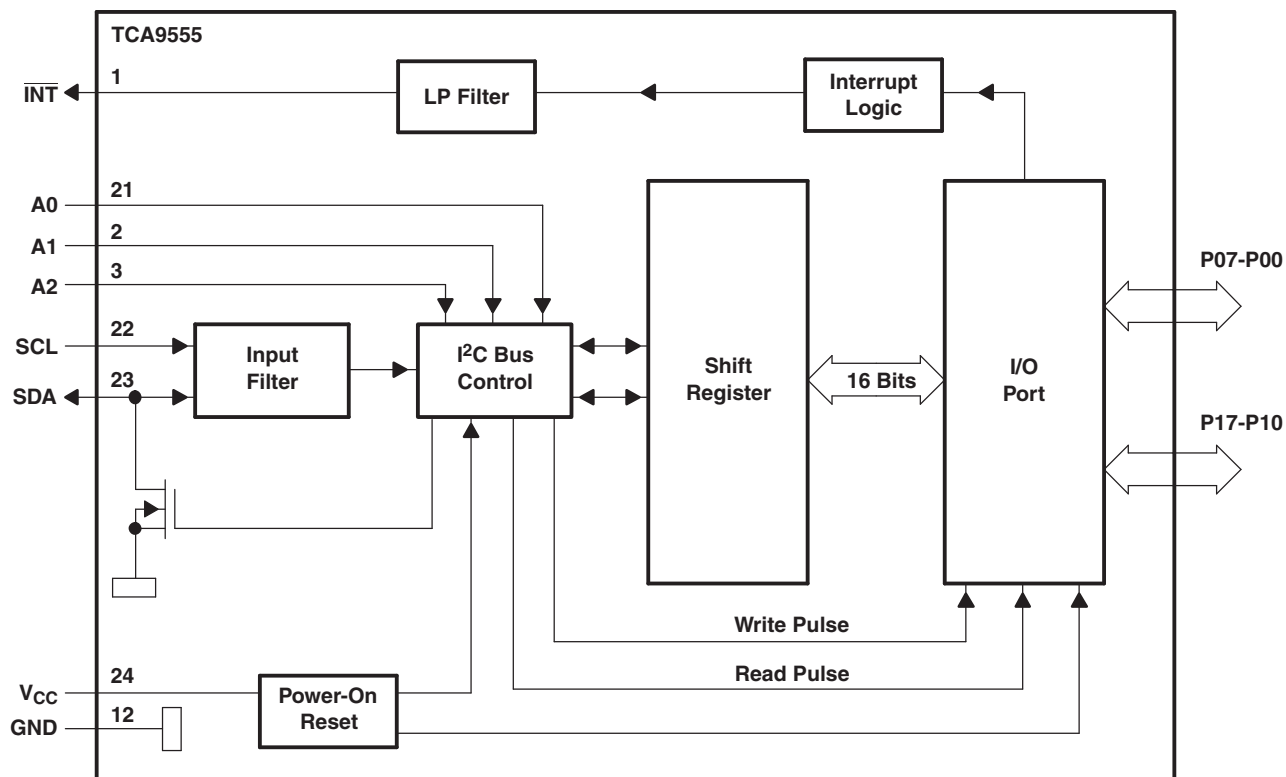

Pin numbers shown are for the PW package.

All I/Os are set to inputs at reset.

Figure 22. Logic Diagram (Positive Logic)

9.3 Feature Description

9.3.1 5-V Tolerant I/O Ports

The TCA9555 features I/O ports which are tolerant of up to 5 V. This allows the TCA9555 to be connected to a large array of devices. To minimize ICC, any inputs must be sure that the input voltage stays within V_{IH} and V_{IL} of the device as described in the [Electrical Characteristics](#) table.

Feature Description (continued)

9.3.2 Hardware Address Pins

The TCA9555 features 3 hardware address pins (A0, A1, and A2) to allow the user to program the device's I²C address by pulling each pin to either V_{CC} or GND to signify the bit value in the address. This allows up to 8 TCA9555 to be on the same bus without address conflicts. See the [Functional Block Diagram](#) to see the 3 pins. The voltage on the pins must not change while the device is powered up in order to prevent possible I²C glitches as a result of the device address changing during a transmission. All of the pins must be tied either to V_{CC} or GND and cannot be left floating.

9.3.3 Interrupt ($\overline{\text{INT}}$) Output

An interrupt is generated by any rising or falling edge of the port inputs in the input mode. After time t_{iv} , the signal INT is valid. Resetting the interrupt circuit is achieved when data on the port is changed to the original setting or data is read from the port that generated the interrupt. Resetting occurs in the read mode at the acknowledge (ACK) bit after the rising edge of the SCL signal. Note that the $\overline{\text{INT}}$ is reset at the ACK just before the byte of changed data is sent. Interrupts that occur during the ACK clock pulse can be lost (or be very short) because of the resetting of the interrupt during this pulse. Each change of the I/Os after resetting is detected and is transmitted as $\overline{\text{INT}}$.

Reading from or writing to another device does not affect the interrupt circuit, and a pin configured as an output cannot cause an interrupt. Changing an I/O from an output to an input may cause a false interrupt to occur if the state of the pin does not match the contents of the Input Port register. Because each 8-bit port is read independently, the interrupt caused by port 0 is not cleared by a read of port 1, or vice versa.

$\overline{\text{INT}}$ has an open-drain structure and requires a pull-up resistor to V_{CC} (typically 10 k Ω in value).

9.4 Device Functional Modes

9.4.1 Power-On Reset (POR)

When power (from 0 V) is applied to V_{CC}, an internal power-on reset circuit holds the TCA9555 in a reset condition until V_{CC} has reached V_{POR}. At that time, the reset condition is released, and the TCA9555 registers and I²C-SMBus state machine initialize to their default states. After that, V_{CC} must be lowered to below V_{PORF} and back up to the operating voltage for a power-reset cycle.

9.4.2 Powered-Up

When power has been applied to V_{CC} above V_{POR}, and the POR has taken place, the device is in a functioning mode. In this state, the device is ready to accept any incoming I²C requests and is monitoring for changes on the input ports.

9.5 Programming

9.5.1 I/O Port

When an I/O is configured as an input, FETs Q1 and Q2 are off, creating a high-impedance input. The input voltage may be raised above V_{CC} to a maximum of 5.5 V.

If the I/O is configured as an output, Q1 or Q2 is enabled, depending on the state of the Output Port register. In this case, there are low-impedance paths between the I/O pin and either V_{CC} or GND. The external voltage applied to this I/O pin must not exceed the recommended levels for proper operation. [Figure 23](#) shows the simplified schematic of P-Port I/Os.

Programming (continued)

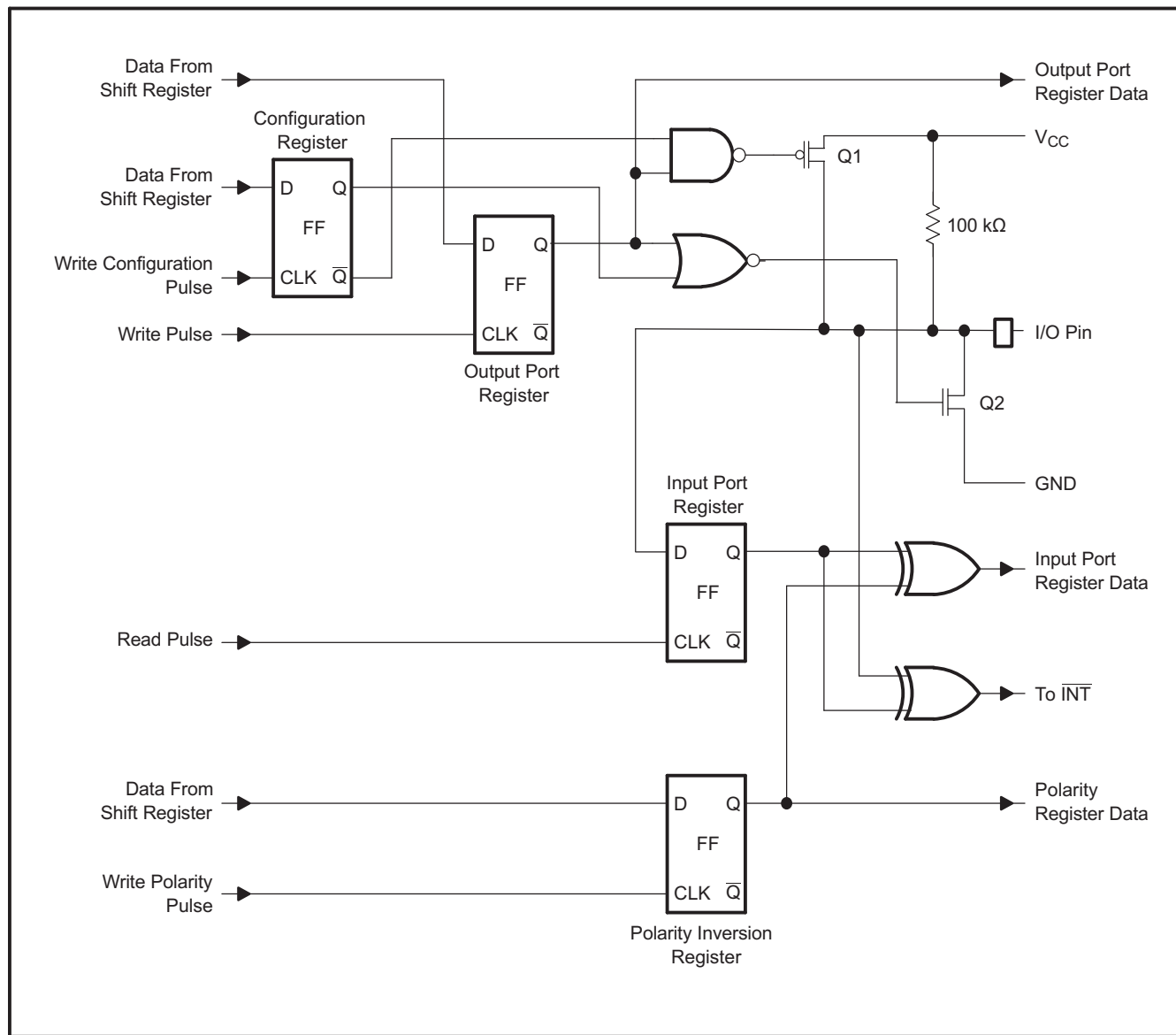

Figure 23. Simplified Schematic of P-Port I/Os

9.5.2 I²C Interface

The TCA9555 has a standard bidirectional I²C interface that is controlled by a master device in order to be configured or read the status of this device. Each slave on the I²C bus has a specific device address to differentiate between other slave devices that are on the same I²C bus. Many slave devices require configuration upon startup to set the behavior of the device. This is typically done when the master accesses internal register maps of the slave, which have unique register addresses. A device can have one or multiple registers where data is stored, written, or read. For more information see the *Understanding the I2C Bus* application report, [SLVA704](#).

The physical I²C interface consists of the serial clock (SCL) and serial data (SDA) lines. Both SDA and SCL lines must be connected to V_{CC} through a pull-up resistor. The size of the pull-up resistor is determined by the amount of capacitance on the I²C lines. For further details, refer to *I²C Pull-up Resistor Calculation* application report, [SLVA689](#). Data transfer may be initiated only when the bus is idle. A bus is considered idle if both SDA and SCL lines are high after a STOP condition.

Programming (continued)

Figure 24 and Figure 25 show the general procedure for a master to access a slave device:

1. If a master wants to send data to a slave:
 - Master-transmitter sends a START condition and addresses the slave-receiver.
 - Master-transmitter sends data to slave-receiver.
 - Master-transmitter terminates the transfer with a STOP condition.
2. If a master wants to receive or read data from a slave:
 - Master-receiver sends a START condition and addresses the slave-transmitter.
 - Master-receiver sends the requested register to read to slave-transmitter.
 - Master-receiver receives data from the slave-transmitter.
 - Master-receiver terminates the transfer with a STOP condition.

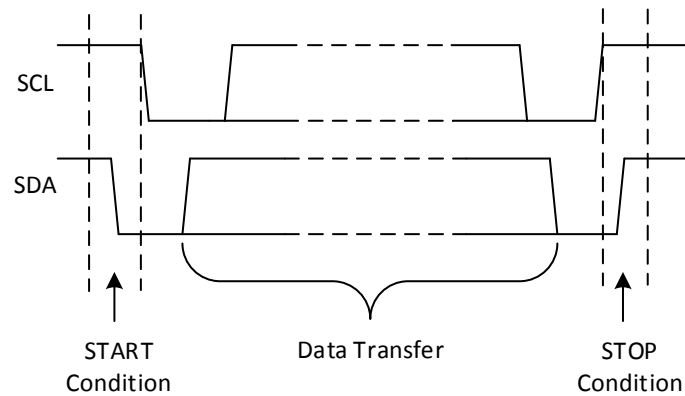

Figure 24. Definition of Start and Stop Conditions

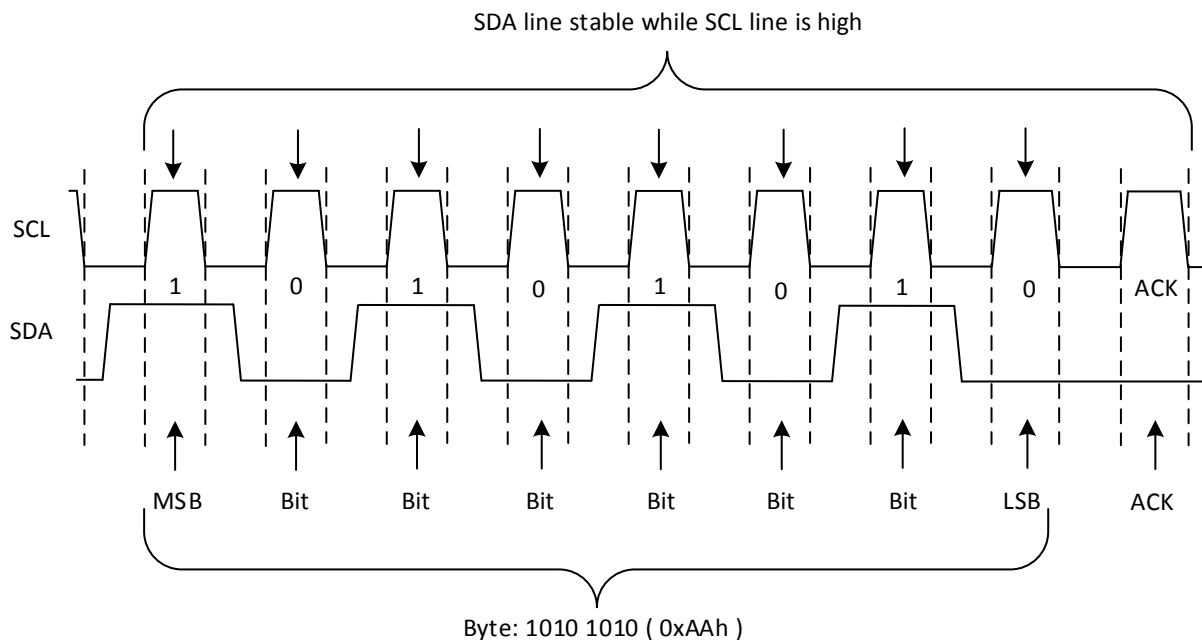

Figure 25. Bit Transfer

Programming (continued)

Table 1 shows the interface definition.

Table 1. Interface Definition

BYTE	BIT							
	7 (MSB)	6	5	4	3	2	1	0 (LSB)
I ² C slave address	L	H	L	L	A2	A1	A0	R/W
P0x I/O data bus	P07	P06	P05	P04	P03	P02	P01	P00
P1x I/O data bus	P17	P16	P15	P14	P13	P12	P11	P10

9.5.2.1 Bus Transactions

Data is exchanged between the master and the TCA9555 through write and read commands, and this is accomplished by reading from or writing to registers in the slave device.

Registers are locations in the memory of the slave which contain information, whether it be the configuration information or some sampled data to send back to the master. The master must write information to these registers in order to instruct the slave device to perform a task.

9.5.2.1.1 Writes

To write on the I²C bus, the master sends a START condition on the bus with the address of the slave, as well as the last bit (the R/W bit) set to 0, which signifies a write. After the slave sends the acknowledge bit, the master then sends the register address of the register to which it wishes to write. The slave acknowledges again, letting the master know it is ready. After this, the master starts sending the register data to the slave until the master has sent all the data necessary (which is sometimes only a single byte), and the master terminates the transmission with a STOP condition.

See the [Control Register and Command Byte](#) section to see list of the TCA9555's internal registers and a description of each one.

Figure 26 to Figure 28 show examples of writing a single byte to a slave register.

- Master controls SDA line
- Slave controls SDA line

Write to one register in a device

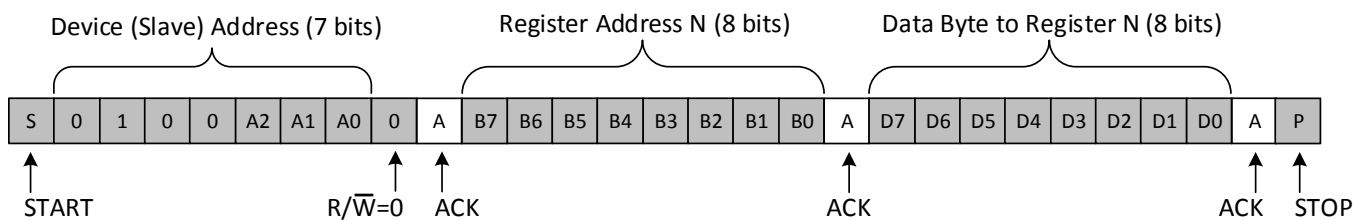

Figure 26. Write to Register

Programming (continued)

- Master controls SDA line
- Slave controls SDA line

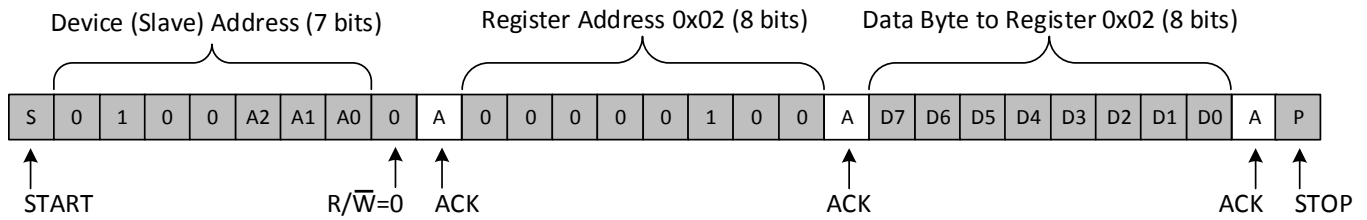

Figure 27. Write to the Polarity Inversion Register

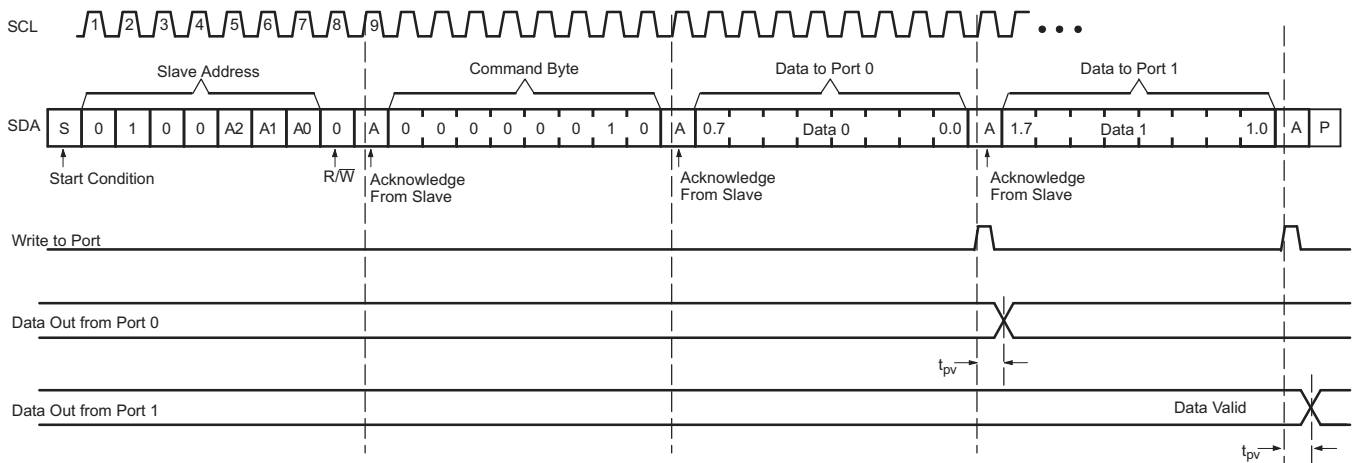

Figure 28. Write to Output Port Registers

Programming (continued)

9.5.2.1.2 Reads

Reading from a slave is very similar to writing, but requires some additional steps. In order to read from a slave, the master must first instruct the slave which register it wishes to read from. This is done by the master starting off the transmission in a similar fashion as the write, by sending the address with the R/W bit equal to 0 (signifying a write), followed by the register address it wishes to read from. When the slave acknowledges this register address, the master sends a START condition again, followed by the slave address with the R/W bit set to 1 (signifying a read). This time, the slave acknowledges the read request, and the master releases the SDA bus but continues supplying the clock to the slave. During this part of the transaction, the master becomes the master-receiver, and the slave becomes the slave-transmitter.

The master continues to send out the clock pulses, but releases the SDA line so that the slave can transmit data. At the end of every byte of data, the master sends an ACK to the slave, letting the slave know that it is ready for more data. When the master has received the number of bytes it is expecting, it sends a NACK, signaling to the slave to halt communications and release the bus. The master follows this up with a STOP condition.

See the [Control Register and Command Byte](#) section to see list of the TCA9555's internal registers and a description of each one.

Figure 29 to Figure 31 show examples of reading a single byte from a slave register.

- Master controls SDA line
- Slave controls SDA line

Read from one register in a device

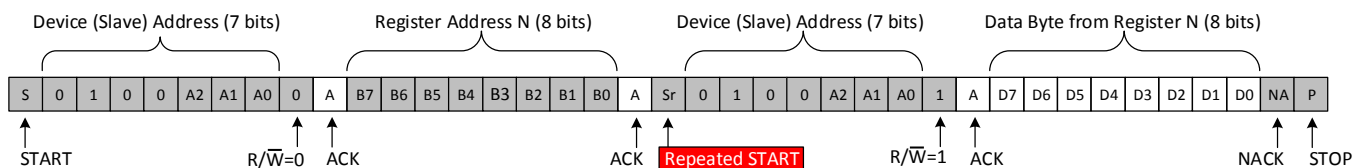
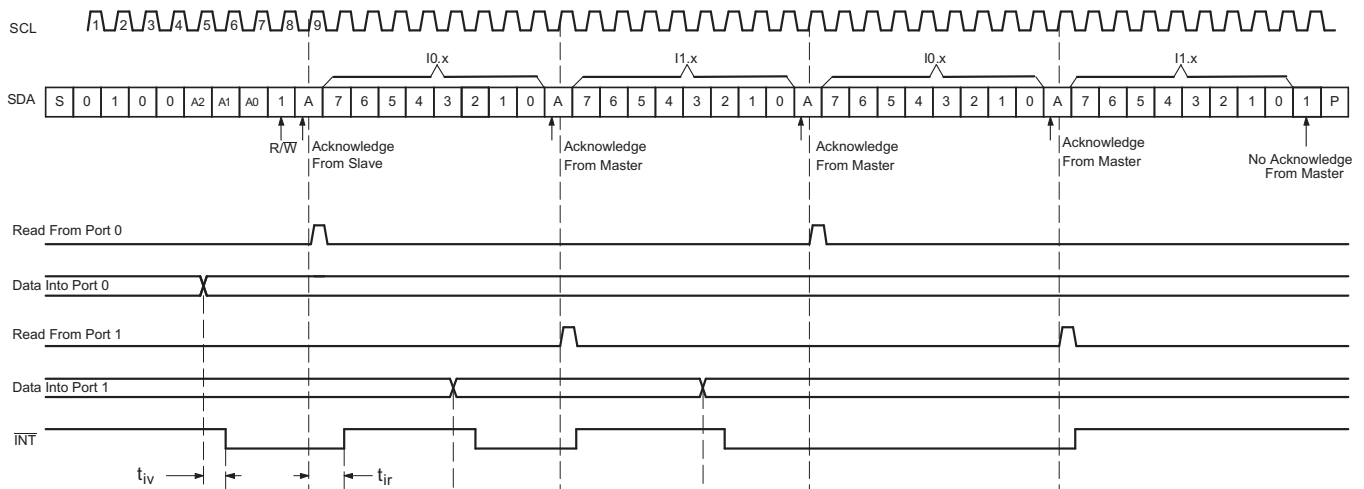

Figure 29. Read from Register

After a restart, the value of the register defined by the command byte matches the register being accessed when the restart occurred. For example, if the command byte references Input Port 1 before the restart, the restart occurs when Input Port 0 is being read. The original command byte is forgotten. If a subsequent restart occurs, Input Port 0 is read first. Data is clocked into the register on the rising edge of the ACK clock pulse. After the first byte is read, additional bytes may be read, but the data now reflect the information in the other register in the pair. For example, if Input Port 1 is read, the next byte read is Input Port 0.

Data is clocked into the register on the rising edge of the ACK clock pulse. There is no limitation on the number of data bytes received in one read transmission, but when the final byte is received, the bus master must not acknowledge the data.

Programming (continued)



- A. Transfer of data can be stopped at any time by a Stop condition. When this occurs, data present at the latest acknowledge phase is valid (output mode). It is assumed that the command byte previously has been set to 00 (read Input Port register).
- B. This figure eliminates the command byte transfer, a restart, and slave address call between the initial slave address call and actual data transfer from the P port.

Figure 30. Read Input Port Register, Scenario 1

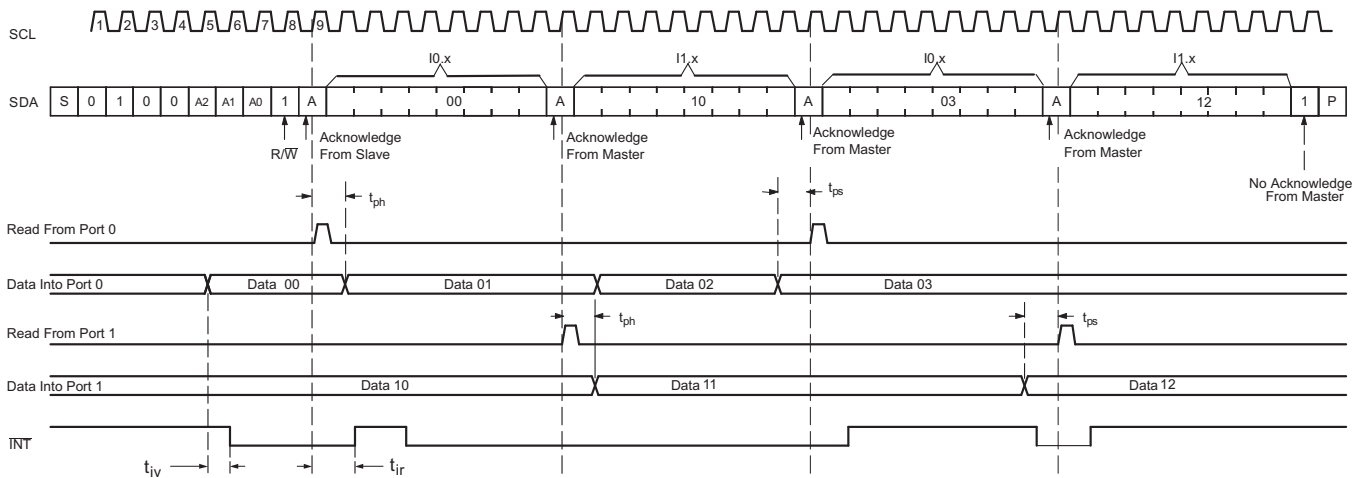

- A. Transfer of data can be stopped at any time by a Stop condition. When this occurs, data present at the latest acknowledge phase is valid (output mode). It is assumed that the command byte previously has been set to 00 (read Input Port register).
- B. This figure eliminates the command byte transfer, a restart, and slave address call between the initial slave address call and actual data transfer from the P port.

Figure 31. Read Input Port Register, Scenario 2

Programming (continued)

9.5.3 Device Address

Figure 32 shows the address byte of the TCA9555.

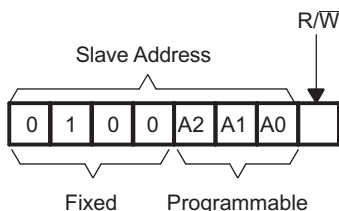

Figure 32. TCA9555 Address

Table 2 shows the TCA9555 address reference.

Table 2. Address Reference

INPUTS			I ² C BUS SLAVE ADDRESS
A2	A1	A0	
L	L	L	32 (decimal), 0x20 (hexadecimal)
L	L	H	33 (decimal), 0x21 (hexadecimal)
L	H	L	34 (decimal), 0x22 (hexadecimal)
L	H	H	35 (decimal), 0x23 (hexadecimal)
H	L	L	36 (decimal), 0x24 (hexadecimal)
H	L	H	37 (decimal), 0x25 (hexadecimal)
H	H	L	38 (decimal), 0x26 (hexadecimal)
H	H	H	39 (decimal), 0x27 (hexadecimal)

The last bit of the slave address defines the operation (read or write) to be performed. A high (1) selects a read operation, while a low (0) selects a write operation.

9.5.4 Control Register and Command Byte

Following the successful acknowledgment of the address byte, the bus master sends a command byte shown in Table 3, that is stored in the control register in the TCA9555. Three bits of this data byte state the operation (read or write) and the internal register (input, output, polarity inversion, or configuration) that is affected. This register can be written or read through the I²C bus. The command byte is sent only during a write transmission.

When a command byte has been sent, the register that was addressed continues to be accessed by reads until a new command byte has been sent. Figure 33 shows the control register bits.

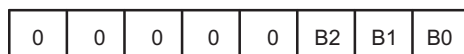

Figure 33. Control Register Bits

Table 3. Command Byte

CONTROL REGISTER BITS			COMMAND BYTE (HEX)	REGISTER	PROTOCOL	POWER-UP DEFAULT
B2	B1	B0				
0	0	0	0x00	Input Port 0	Read byte	xxxx xxxx
0	0	1	0x01	Input Port 1	Read byte	xxxx xxxx
0	1	0	0x02	Output Port 0	Read-write byte	1111 1111
0	1	1	0x03	Output Port 1	Read-write byte	1111 1111
1	0	0	0x04	Polarity Inversion Port 0	Read-write byte	0000 0000
1	0	1	0x05	Polarity Inversion Port 1	Read-write byte	0000 0000

Table 3. Command Byte (continued)

CONTROL REGISTER BITS			COMMAND BYTE (HEX)	REGISTER	PROTOCOL	POWER-UP DEFAULT
B2	B1	B0				
1	1	0	0x06	Configuration Port 0	Read-write byte	1111 1111
1	1	1	0x07	Configuration Port 1	Read-write byte	1111 1111

9.6 Register Maps

9.6.1 Register Descriptions

The Input Port registers (registers 0 and 1) shown in [Table 4](#) reflect the incoming logic levels of the pins, regardless of whether the pin is defined as an input or an output by the Configuration register. It only acts on read operation. Writes to these registers have no effect. The default value, X, is determined by the externally applied logic level.

Before a read operation, a write transmission is sent with the command byte to indicate to the I²C device that the Input Port register is accessed next.

Table 4. Registers 0 and 1 (Input Port Registers)

Bit	I0.7	I0.6	I0.5	I0.4	I0.3	I0.2	I0.1	I0.0
Default	X	X	X	X	X	X	X	X
Bit	I1.7	I1.6	I1.5	I1.4	I1.3	I1.2	I1.1	I1.0
Default	X	X	X	X	X	X	X	X

The Output Port registers (registers 2 and 3) shown in [Table 5](#) show the outgoing logic levels of the pins defined as outputs by the Configuration register. Bit values in this register have no effect on pins defined as inputs. In turn, reads from this register reflect the value that is in the flip-flop controlling the output selection, not the actual pin value.

Table 5. Registers 2 and 3 (Output Port Registers)

Bit	O0.7	O0.6	O0.5	O0.4	O0.3	O0.2	O0.1	O0.0
Default	1	1	1	1	1	1	1	1
Bit	O1.7	O1.6	O1.5	O1.4	O1.3	O1.2	O1.1	O1.0
Default	1	1	1	1	1	1	1	1

The Polarity Inversion registers (registers 4 and 5) shown in [Table 6](#) allow polarity inversion of pins defined as inputs by the Configuration register. If a bit in this register is set (written with 1), the corresponding port pin's polarity is inverted. If a bit in this register is cleared (written with a 0), the corresponding port pin's original polarity is retained.

Table 6. Registers 4 and 5 (Polarity Inversion Registers)

Bit	N0.7	N0.6	N0.5	N0.4	N0.3	N0.2	N0.1	N0.0
Default	0	0	0	0	0	0	0	0
Bit	N1.7	N1.6	N1.5	N1.4	N1.3	N1.2	N1.1	N1.0
Default	0	0	0	0	0	0	0	0

The Configuration registers (registers 6 and 7) shown in [Table 7](#) configure the directions of the I/O pins. If a bit in this register is set to 1, the corresponding port pin is enabled as an input with a high-impedance output driver. If a bit in this register is cleared to 0, the corresponding port pin is enabled as an output.

Table 7. Registers 6 and 7 (Configuration Registers)

Bit	C0.7	C0.6	C0.5	C0.4	C0.3	C0.2	C0.1	C0.0
Default	1	1	1	1	1	1	1	1
Bit	C1.7	C1.6	C1.5	C1.4	C1.3	C1.2	C1.1	C1.0
Default	1	1	1	1	1	1	1	1

10 Application and Implementation

NOTE

Information in the following applications sections is not part of the TI component specification, and TI does not warrant its accuracy or completeness. TI's customers are responsible for determining suitability of components for their purposes. Customers should validate and test their design implementation to confirm system functionality.

10.1 Application Information

Applications of the TCA9555 has this device connected as a slave to an I²C master (processor), and the I²C bus may contain any number of other slave devices. The TCA9555 is typically be in a remote location from the master, placed close to the GPIOs to which the master needs to monitor or control.

IO Expanders such as the TCA9555 are typically used for controlling LEDs (for feedback or status lights), controlling enable or reset signals of other devices, and even reading the outputs of other devices or buttons.

10.2 Typical Application

Figure 34 shows an application in which the TCA9555 can be used to control multiple subsystems, and even read inputs from buttons.

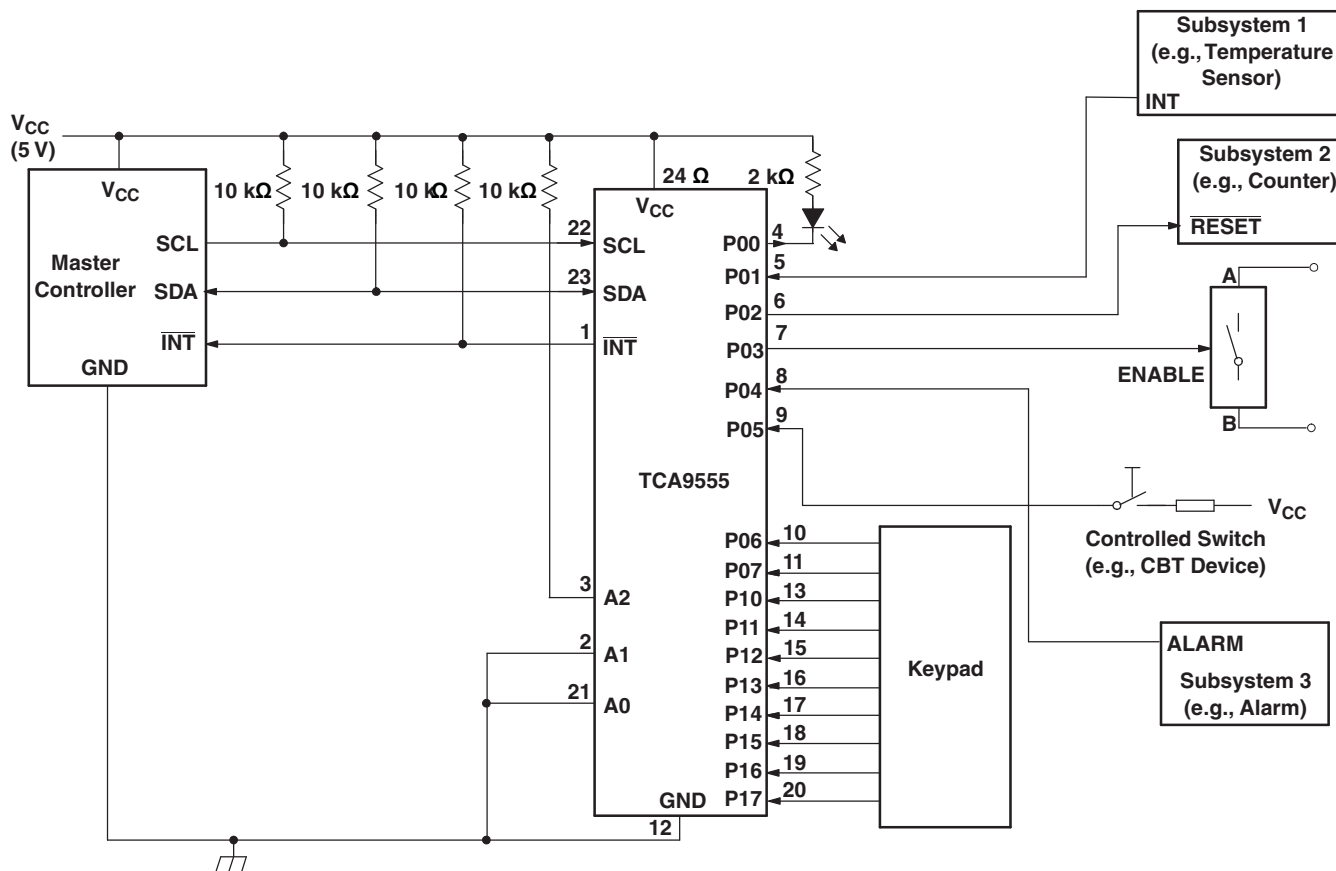

- Device address is configured as 0100100 for this example.
- P00, P02, and P03 are configured as outputs.
- P01, P04–P07, and P10–P17 are configured as inputs.
- Pin numbers shown are for the PW package.

Figure 34. Typical Application

Typical Application (continued)

10.2.1 Design Requirements

The designer must take into consideration the system, to be sure not to violate any of the parameters. [Table 8](#) shows some key parameters which must not be violated.

Table 8. Design Parameters

DESIGN PARAMETER	EXAMPLE VALUE
I ² C and Subsystem Voltage (V _{CC})	5 V
Output current rating, P-port sinking (I _{OL})	25 mA
I ² C bus clock (SCL) speed	400 kHz

10.2.2 Detailed Design Procedure

10.2.2.1 Calculating Junction Temperature and Power Dissipation

When designing with this device, it is important that the [Recommended Operating Conditions](#) not be violated. Many of the parameters of this device are rated based on junction temperature. So junction temperature must be calculated in order to verify that safe operation of the device is met. The basic equation for junction temperature is shown in [Equation 1](#).

$$T_j = T_A + (\theta_{JA} \times P_d) \quad (1)$$

θ_{JA} is the standard junction to ambient thermal resistance measurement of the package, as seen in the [Thermal Information](#) table. P_d is the total power dissipation of the device, and the approximation is shown in [Equation 2](#).

$$P_d \approx (I_{CC_STATIC} \times V_{CC}) + \sum P_{d_PORT_L} + \sum P_{d_PORT_H} \quad (2)$$

[Equation 2](#) is the approximation of power dissipation in the device. The equation is the static power plus the summation of power dissipated by each port (with a different equation based on if the port is outputting high, or outputting low. If the port is set as an input, then power dissipation is the input leakage of the pin multiplied by the voltage on the pin). Note that this ignores power dissipation in the INT and SDA pins, assuming these transients to be small. They can easily be included in the power dissipation calculation by using [Equation 3](#) to calculate the power dissipation in INT or SDA while they are pulling low, and this gives maximum power dissipation.

$$P_{d_PORT_L} = (I_{OL} \times V_{OL}) \quad (3)$$

[Equation 3](#) shows the power dissipation for a single port which is set to output low. The power dissipated by the port is the V_{OL} of the port multiplied by the current it is sinking.

$$P_{d_PORT_H} = (I_{OH} \times (V_{CC} - V_{OH})) \quad (4)$$

[Equation 4](#) shows the power dissipation for a single port which is set to output high. The power dissipated by the port is the current sourced by the port multiplied by the voltage drop across the device (difference between V_{CC} and the output voltage).

10.2.2.2 Minimizing I_{CC} When I/O Is Used to Control LED

When an I/O is used to control an LED, normally it is connected to V_{CC} through a resistor as shown in [Figure 34](#). Because the LED acts as a diode, when the LED is off, the I/O V_{IN} is about 1.2 V less than V_{CC} . The ΔI_{CC} parameter in the [Electrical Characteristics](#) table shows how I_{CC} increases as V_{IN} becomes lower than V_{CC} . For battery-powered applications, it is essential that the voltage of I/O pins is greater than or equal to V_{CC} when the LED is off to minimize current consumption.

[Figure 35](#) shows a high-value resistor in parallel with the LED. [Figure 36](#) shows V_{CC} less than the LED supply voltage by at least 1.2 V. Both of these methods maintain the I/O V_{IN} at or above V_{CC} and prevent additional supply current consumption when the LED is off.

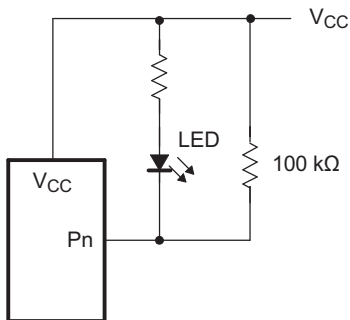

Figure 35. High-Value Resistor in Parallel With LED

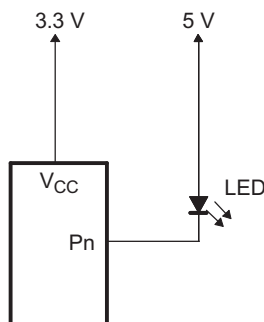

Figure 36. Device Supplied by Lower Voltage

10.2.2.3 Pull-Up Resistor Calculation

The pull-up resistors, R_p , for the SCL and SDA lines need to be selected appropriately and take into consideration the total capacitance of all slaves on the I²C bus. The minimum pull-up resistance is a function of V_{CC} , $V_{OL(max)}$, and I_{OL} as shown in Equation 5.

$$R_{p(min)} = \frac{V_{CC} - V_{OL(max)}}{I_{OL}} \tag{5}$$

The maximum pull-up resistance is a function of the maximum rise time, t_r (300 ns for fast-mode operation, $f_{SCL} = 400$ kHz) and bus capacitance, C_b as shown in Equation 6.

$$R_{p(max)} = \frac{t_r}{0.8473 \times C_b} \tag{6}$$

The maximum bus capacitance for an I²C bus must not exceed 400 pF for standard-mode or fast-mode operation. The bus capacitance can be approximated by adding the capacitance of the TCA9555, C_i for SCL or C_{io} for SDA, the capacitance of wires, connections and traces, and the capacitance of additional slaves on the bus. For further details, see the I²C Pull-up Resistor Calculation application report, SLVA689.

10.2.3 Application Curves

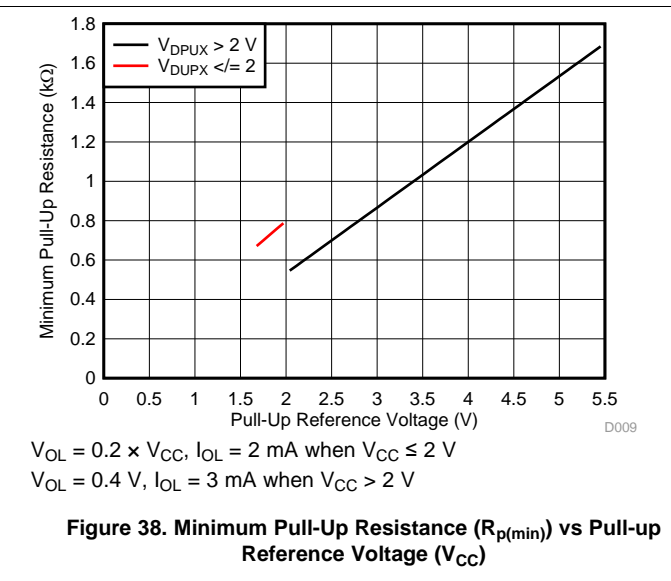
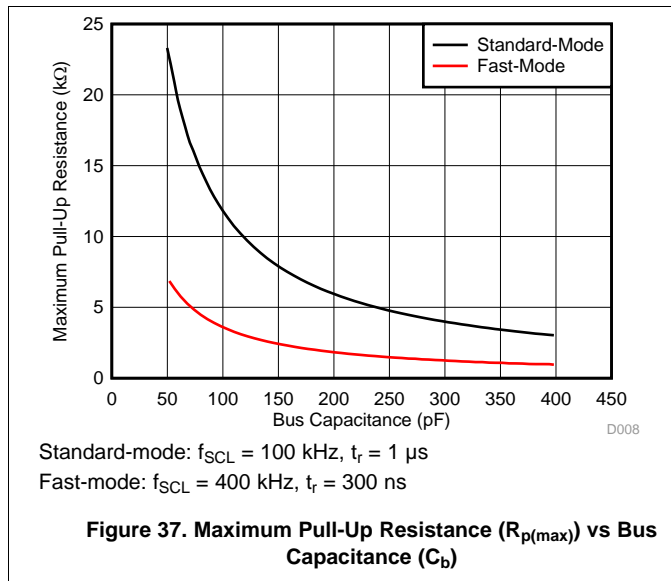

11 Power Supply Recommendations

In the event of a glitch (data output or input or even power) or data corruption, the TCA9555 can be reset to its default conditions by using the power-on reset feature. Power-on reset requires that the device go through a power cycle to be completely reset. This reset also happens when the device is powered on for the first time in an application.

The two types of power-on reset are shown in Figure 39 and Figure 40.

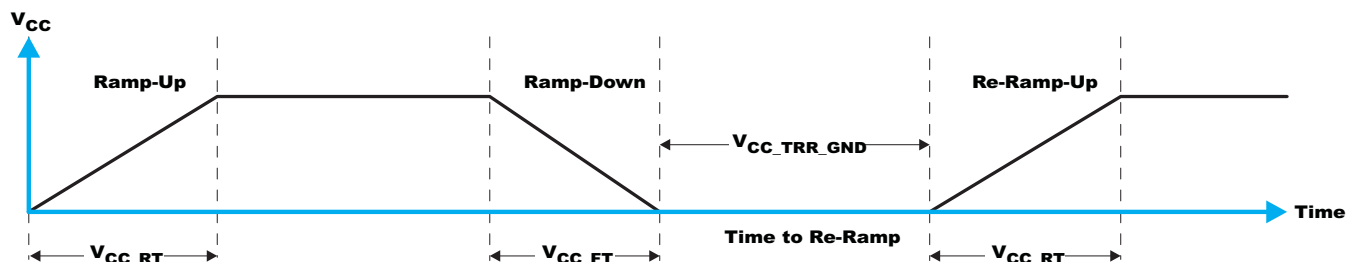

Figure 39. V_{CC} is Lowered Below 0.2 V or 0 V and Then Ramped Up to V_{CC}

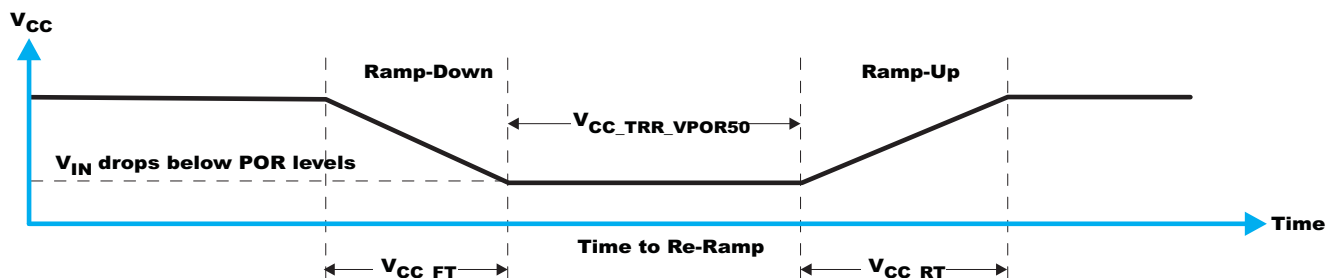

Figure 40. V_{CC} is Lowered Below the POR Threshold, Then Ramped Back Up to V_{CC}

Table 9 specifies the performance of the power-on reset feature for TCA9555 for both types of power-on reset.

Table 9. RECOMMENDED SUPPLY SEQUENCING AND RAMP RATES⁽¹⁾

PARAMETER			MIN	TYP	MAX	UNIT
V_{CC_FT}	Fall rate of V_{CC}	See Figure 39	0.1		2000	ms
V_{CC_RT}	Rise rate of V_{CC}	See Figure 39	0.1		2000	ms
$V_{CC_TRR_GND}$	Time to re-ramp (when V_{CC} drops to GND)	See Figure 39	1			μ s
$V_{CC_TRR_POR50}$	Time to re-ramp (when V_{CC} drops to $V_{POR_MIN} - 50$ mV)	See Figure 40	1			μ s
V_{CC_GH}	Level that V_{CCP} can glitch down to, but not cause a functional disruption when V_{CC_GW}	See Figure 41			1.2	V
V_{CC_MV}	The minimum voltage that V_{CC} can glitch down to without causing a reset (V_{CC_GH} must also not be violated)	See Figure 41	1.5			V
V_{CC_GW}	Glitch width that does not cause a functional disruption	See Figure 41			10	μ s

(1) $T_A = -40^\circ\text{C}$ to $+85^\circ\text{C}$ (unless otherwise noted)

Glitches in the power supply can also affect the power-on reset performance of this device. The glitch width (V_{CC_GW}) and height (V_{CC_GH}) are dependent on each other. The bypass capacitance, source impedance, and device impedance are factors that affect power-on reset performance. Figure 41 and Table 9 provide more information on how to measure these specifications.

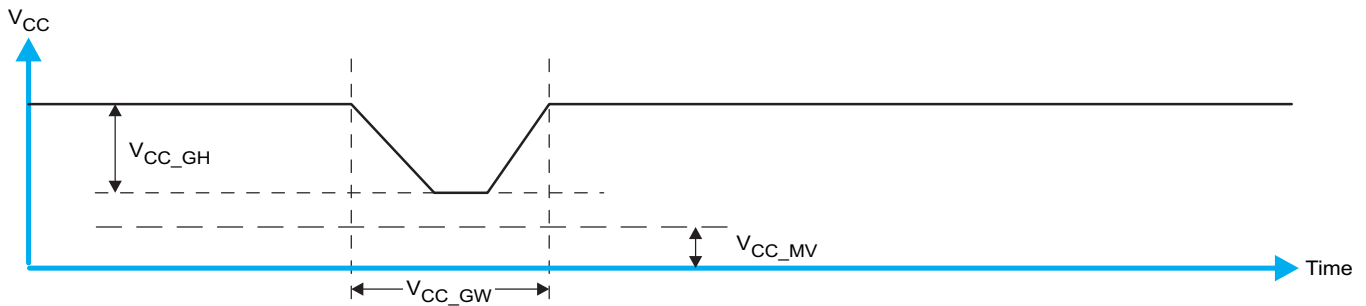

Figure 41. Glitch Width and Glitch Height

V_{POR} is critical to the power-on reset. V_{POR} is the voltage level at which the reset condition is released and all the registers and the I²C/SMBus state machine are initialized to their default states. The value of V_{POR} differs based on the V_{CC} being lowered to or from 0. Figure 42 and Table 9 provide more details on this specification.

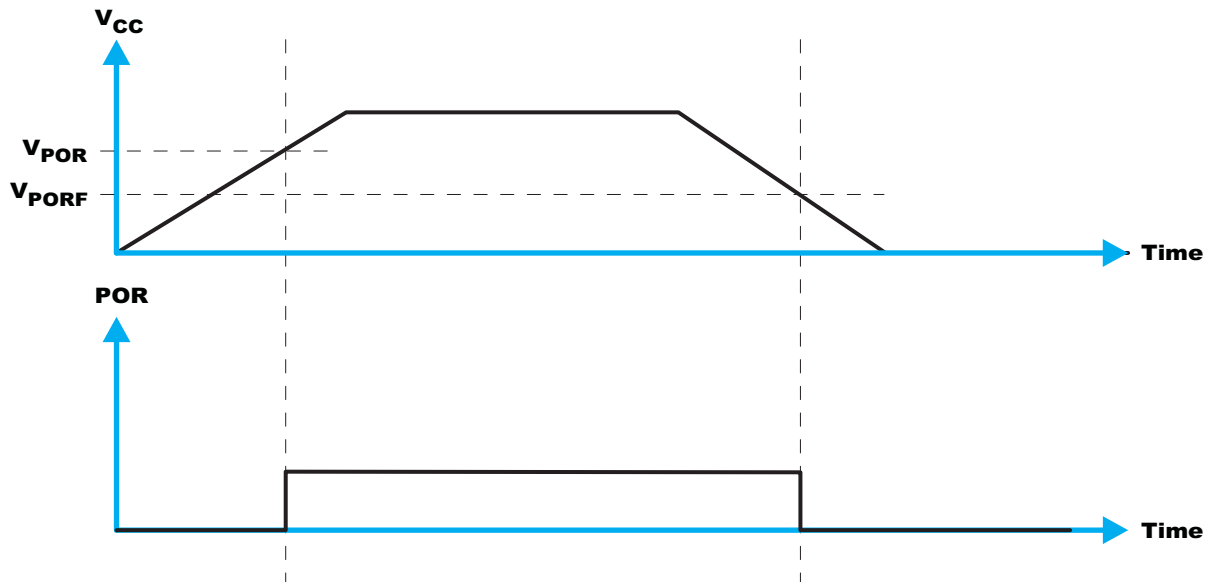

Figure 42. V_{POR}

12 Layout

12.1 Layout Guidelines

For printed circuit board (PCB) layout of the TCA9555, common PCB layout practices must be followed, but additional concerns related to high-speed data transfer such as matched impedances and differential pairs are not a concern for I²C signal speeds.

In all PCB layouts, it is a best practice to avoid right angles in signal traces, to fan out signal traces away from each other upon leaving the vicinity of an integrated circuit (IC), and to use thicker trace widths to carry higher amounts of current that commonly pass through power and ground traces. By-pass and de-coupling capacitors are commonly used to control the voltage on the V_{CC} pin, using a larger capacitor to provide additional power in the event of a short power supply glitch and a smaller capacitor to filter out high-frequency ripple. These capacitors must be placed as close to the TCA9555 as possible. These best practices are shown in the *Layout Example*.

For the layout example provided in the *Layout Example*, it is possible to fabricate a PCB with only 2 layers by using the top layer for signal routing and the bottom layer as a split plane for power (V_{CC}) and ground (GND). However, a 4 layer board is preferable for boards with higher density signal routing. On a 4 layer PCB, it is common to route signals on the top and bottom layer, dedicate one internal layer to a ground plane, and dedicate the other internal layer to a power plane. In a board layout using planes or split planes for power and ground, vias are placed directly next to the surface mount component pad which needs to attach to V_{CC}, or GND and the via is connected electrically to the internal layer or the other side of the board. Vias are also used when a signal trace needs to be routed to the opposite side of the board, but this technique is not demonstrated in the *Layout Example*.

12.2 Layout Example

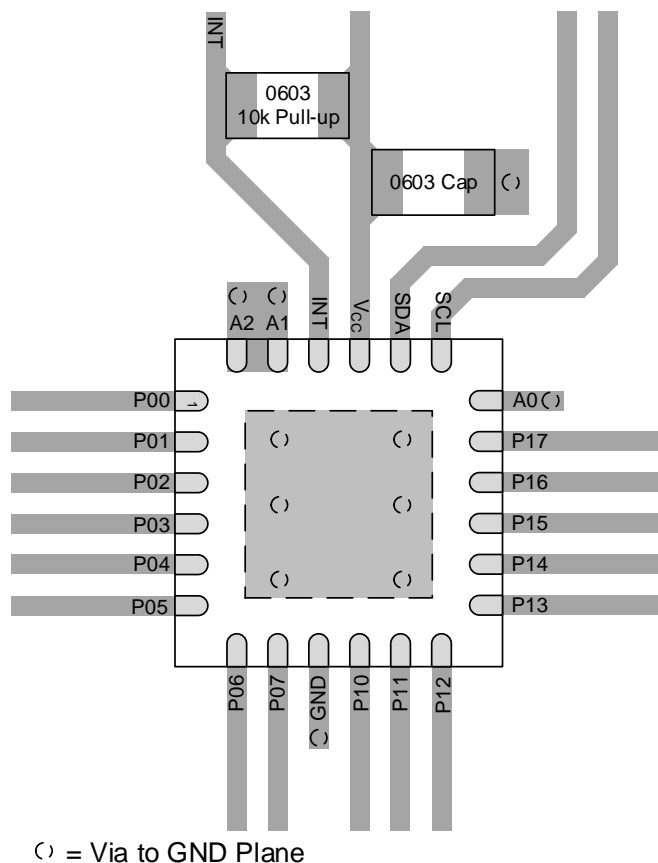

Figure 43. TCA9555 Layout Example

13 器件和文档支持

13.1 文档支持

13.1.1 相关文档

请参阅如下相关文档：

- P_C 上拉电阻器计算, [SLVA689](#)
- 《I2C 总线在采用中继器时的最高时钟频率》, [SLVA695](#)
- 《逻辑器件简介》, [SLVA700](#)
- 《了解 I2C 总线》, [SLVA704](#)
- 《IO 扩展器 EVM 用户指南》, [SLVUA59A](#)

13.2 接收文档更新通知

要接收文档更新通知, 请导航至 TI.com.cn 上的器件产品文件夹。单击右上角的 **通知我** 进行注册, 即可每周接收产品信息更改摘要。有关更改的详细信息, 请查看任何已修订文档中包含的修订历史记录。

13.3 社区资源

下列链接提供到 TI 社区资源的连接。链接的内容由各个分销商“按照原样”提供。这些内容并不构成 TI 技术规范, 并且不一定反映 TI 的观点; 请参阅 TI 的 [《使用条款》](#)。

TI E2E™ Online Community *TI's Engineer-to-Engineer (E2E) Community*. Created to foster collaboration among engineers. At e2e.ti.com, you can ask questions, share knowledge, explore ideas and help solve problems with fellow engineers.

Design Support *TI's Design Support* Quickly find helpful E2E forums along with design support tools and contact information for technical support.

13.4 商标

E2E is a trademark of Texas Instruments.

All other trademarks are the property of their respective owners.

13.5 静电放电警告



ESD 可能会损坏该集成电路。德州仪器 (TI) 建议通过适当的预防措施处理所有集成电路。如果不遵守正确的处理措施和安装程序, 可能会损坏集成电路。

ESD 的损坏小至导致微小的性能降级, 大至整个器件故障。精密的集成电路可能更容易受到损坏, 这是因为非常细微的参数更改都可能会导致器件与其发布的规格不相符。

13.6 术语表

[SLYZ022](#) — TI 术语表。

这份术语表列出并解释术语、缩写和定义。

14 机械、封装和可订购信息

以下页面包含机械、封装和可订购信息。这些信息是指定器件的最新可用数据。数据如有变更, 恕不另行通知, 且不会对此文档进行修订。如需获取此产品说明书的浏览器版本, 请查阅左侧的导航栏。

PACKAGING INFORMATION

Orderable part number	Status (1)	Material type (2)	Package Pins	Package qty Carrier	RoHS (3)	Lead finish/ Ball material (4)	MSL rating/ Peak reflow (5)	Op temp (°C)	Part marking (6)
TCA9555DBR	Active	Production	SSOP (DB) 24	2000 LARGE T&R	Yes	NIPDAU	Level-1-260C-UNLIM	-40 to 85	TD9555
TCA9555DBR.A	Active	Production	SSOP (DB) 24	2000 LARGE T&R	Yes	NIPDAU	Level-1-260C-UNLIM	-40 to 85	TD9555
TCA9555DBT	Active	Production	SSOP (DB) 24	250 SMALL T&R	Yes	NIPDAU	Level-1-260C-UNLIM	-40 to 85	TD9555
TCA9555DBT.A	Active	Production	SSOP (DB) 24	250 SMALL T&R	Yes	NIPDAU	Level-1-260C-UNLIM	-40 to 85	TD9555
TCA9555PWR	Active	Production	TSSOP (PW) 24	2000 LARGE T&R	Yes	NIPDAU	Level-1-260C-UNLIM	-40 to 85	PW555
TCA9555PWR.A	Active	Production	TSSOP (PW) 24	2000 LARGE T&R	Yes	NIPDAU	Level-1-260C-UNLIM	-40 to 85	PW555
TCA9555PWR.B	Active	Production	TSSOP (PW) 24	2000 LARGE T&R	Yes	NIPDAU	Level-1-260C-UNLIM	-40 to 85	PW555
TCA9555PWRG4	Active	Production	TSSOP (PW) 24	2000 LARGE T&R	Yes	NIPDAU	Level-1-260C-UNLIM	-40 to 85	PW555
TCA9555PWRG4.A	Active	Production	TSSOP (PW) 24	2000 LARGE T&R	Yes	NIPDAU	Level-1-260C-UNLIM	-40 to 85	PW555
TCA9555PWRG4.B	Active	Production	TSSOP (PW) 24	2000 LARGE T&R	Yes	NIPDAU	Level-1-260C-UNLIM	-40 to 85	PW555
TCA9555RGER	Active	Production	VQFN (RGE) 24	3000 LARGE T&R	Yes	NIPDAU	Level-1-260C-UNLIM	-40 to 85	TD9555
TCA9555RGER.A	Active	Production	VQFN (RGE) 24	3000 LARGE T&R	Yes	NIPDAU	Level-1-260C-UNLIM	-40 to 85	TD9555
TCA9555RGER.B	Active	Production	VQFN (RGE) 24	3000 LARGE T&R	-	NIPDAU	Level-1-260C-UNLIM	-40 to 85	TD9555
TCA9555RGERG4	Active	Production	VQFN (RGE) 24	3000 LARGE T&R	Yes	NIPDAU	Level-1-260C-UNLIM	-40 to 85	TD9555
TCA9555RGERG4.A	Active	Production	VQFN (RGE) 24	3000 LARGE T&R	Yes	NIPDAU	Level-1-260C-UNLIM	-40 to 85	TD9555
TCA9555RTWR	Active	Production	WQFN (RTW) 24	3000 LARGE T&R	Yes	NIPDAU NIPDAU	Level-2-260C-1 YEAR	-40 to 85	PW555
TCA9555RTWR.A	Active	Production	WQFN (RTW) 24	3000 LARGE T&R	Yes	NIPDAU	Level-2-260C-1 YEAR	-40 to 85	PW555
TCA9555RTWR.B	Active	Production	WQFN (RTW) 24	3000 LARGE T&R	Yes	NIPDAU	Level-2-260C-1 YEAR	-40 to 85	PW555
TCA9555RTWRG4	Active	Production	WQFN (RTW) 24	3000 LARGE T&R	Yes	NIPDAU	Level-2-260C-1 YEAR	-40 to 85	PW555
TCA9555RTWRG4.A	Active	Production	WQFN (RTW) 24	3000 LARGE T&R	Yes	NIPDAU	Level-2-260C-1 YEAR	-40 to 85	PW555
TCA9555RTWRG4.B	Active	Production	WQFN (RTW) 24	3000 LARGE T&R	Yes	NIPDAU	Level-2-260C-1 YEAR	-40 to 85	PW555

(1) **Status:** For more details on status, see our [product life cycle](#).

(2) **Material type:** When designated, preproduction parts are prototypes/experimental devices, and are not yet approved or released for full production. Testing and final process, including without limitation quality assurance, reliability performance testing, and/or process qualification, may not yet be complete, and this item is subject to further changes or possible discontinuation. If available for ordering, purchases will be subject to an additional waiver at checkout, and are intended for early internal evaluation purposes only. These items are sold without warranties of any kind.

(3) **RoHS values:** Yes, No, RoHS Exempt. See the [TI RoHS Statement](#) for additional information and value definition.

(4) **Lead finish/Ball material:** Parts may have multiple material finish options. Finish options are separated by a vertical ruled line. Lead finish/Ball material values may wrap to two lines if the finish value exceeds the maximum column width.

(5) **MSL rating/Peak reflow:** The moisture sensitivity level ratings and peak solder (reflow) temperatures. In the event that a part has multiple moisture sensitivity ratings, only the lowest level per JEDEC standards is shown. Refer to the shipping label for the actual reflow temperature that will be used to mount the part to the printed circuit board.

(6) **Part marking:** There may be an additional marking, which relates to the logo, the lot trace code information, or the environmental category of the part.

Multiple part markings will be inside parentheses. Only one part marking contained in parentheses and separated by a "~" will appear on a part. If a line is indented then it is a continuation of the previous line and the two combined represent the entire part marking for that device.

Important Information and Disclaimer: The information provided on this page represents TI's knowledge and belief as of the date that it is provided. TI bases its knowledge and belief on information provided by third parties, and makes no representation or warranty as to the accuracy of such information. Efforts are underway to better integrate information from third parties. TI has taken and continues to take reasonable steps to provide representative and accurate information but may not have conducted destructive testing or chemical analysis on incoming materials and chemicals. TI and TI suppliers consider certain information to be proprietary, and thus CAS numbers and other limited information may not be available for release.

In no event shall TI's liability arising out of such information exceed the total purchase price of the TI part(s) at issue in this document sold by TI to Customer on an annual basis.

TAPE AND REEL INFORMATION

QUADRANT ASSIGNMENTS FOR PIN 1 ORIENTATION IN TAPE

*All dimensions are nominal

Device	Package Type	Package Drawing	Pins	SPQ	Reel Diameter (mm)	Reel Width W1 (mm)	A0 (mm)	B0 (mm)	K0 (mm)	P1 (mm)	W (mm)	Pin1 Quadrant
TCA9555DBR	SSOP	DB	24	2000	330.0	16.4	8.2	8.8	2.5	12.0	16.0	Q1
TCA9555DBT	SSOP	DB	24	250	330.0	16.4	8.2	8.8	2.5	12.0	16.0	Q1
TCA9555RGER	VQFN	RGE	24	3000	330.0	12.4	4.25	4.25	1.15	8.0	12.0	Q2
TCA9555RGERG4	VQFN	RGE	24	3000	330.0	12.4	4.25	4.25	1.15	8.0	12.0	Q2
TCA9555RTWR	WQFN	RTW	24	3000	330.0	12.4	4.25	4.25	1.15	8.0	12.0	Q2
TCA9555RTWR	WQFN	RTW	24	3000	330.0	12.4	4.25	4.25	1.15	8.0	12.0	Q2
TCA9555RTWRG4	WQFN	RTW	24	3000	330.0	12.4	4.25	4.25	1.15	8.0	12.0	Q2

TAPE AND REEL BOX DIMENSIONS

*All dimensions are nominal

Device	Package Type	Package Drawing	Pins	SPQ	Length (mm)	Width (mm)	Height (mm)
TCA9555DBR	SSOP	DB	24	2000	353.0	353.0	32.0
TCA9555DBT	SSOP	DB	24	250	353.0	353.0	32.0
TCA9555RGER	VQFN	RGE	24	3000	346.0	346.0	33.0
TCA9555RGERG4	VQFN	RGE	24	3000	346.0	346.0	33.0
TCA9555RTWR	WQFN	RTW	24	3000	367.0	367.0	35.0
TCA9555RTWR	WQFN	RTW	24	3000	353.0	353.0	32.0
TCA9555RTWRG4	WQFN	RTW	24	3000	367.0	367.0	35.0

RGE 24

GENERIC PACKAGE VIEW

VQFN - 1 mm max height

PLASTIC QUAD FLATPACK - NO LEAD

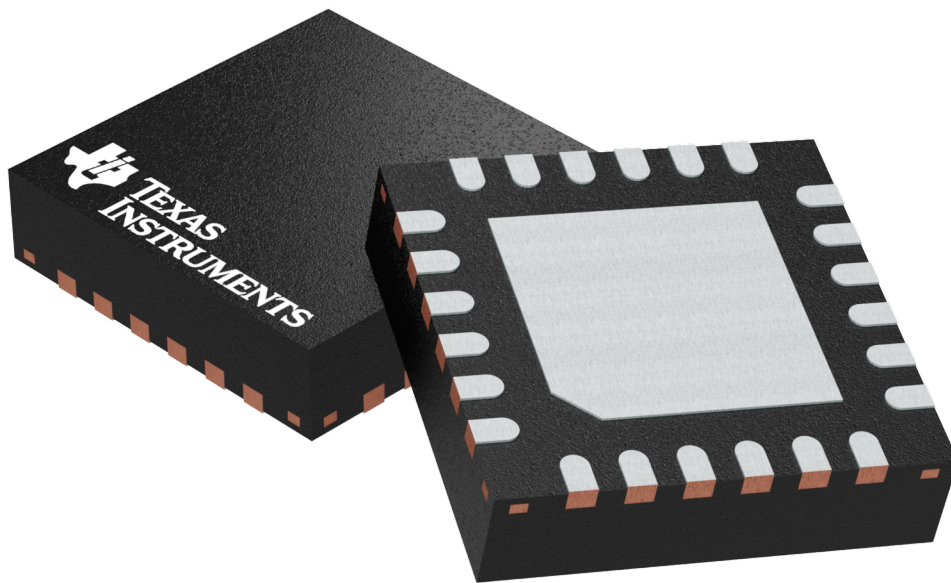

Images above are just a representation of the package family, actual package may vary.
Refer to the product data sheet for package details.

4204104/H

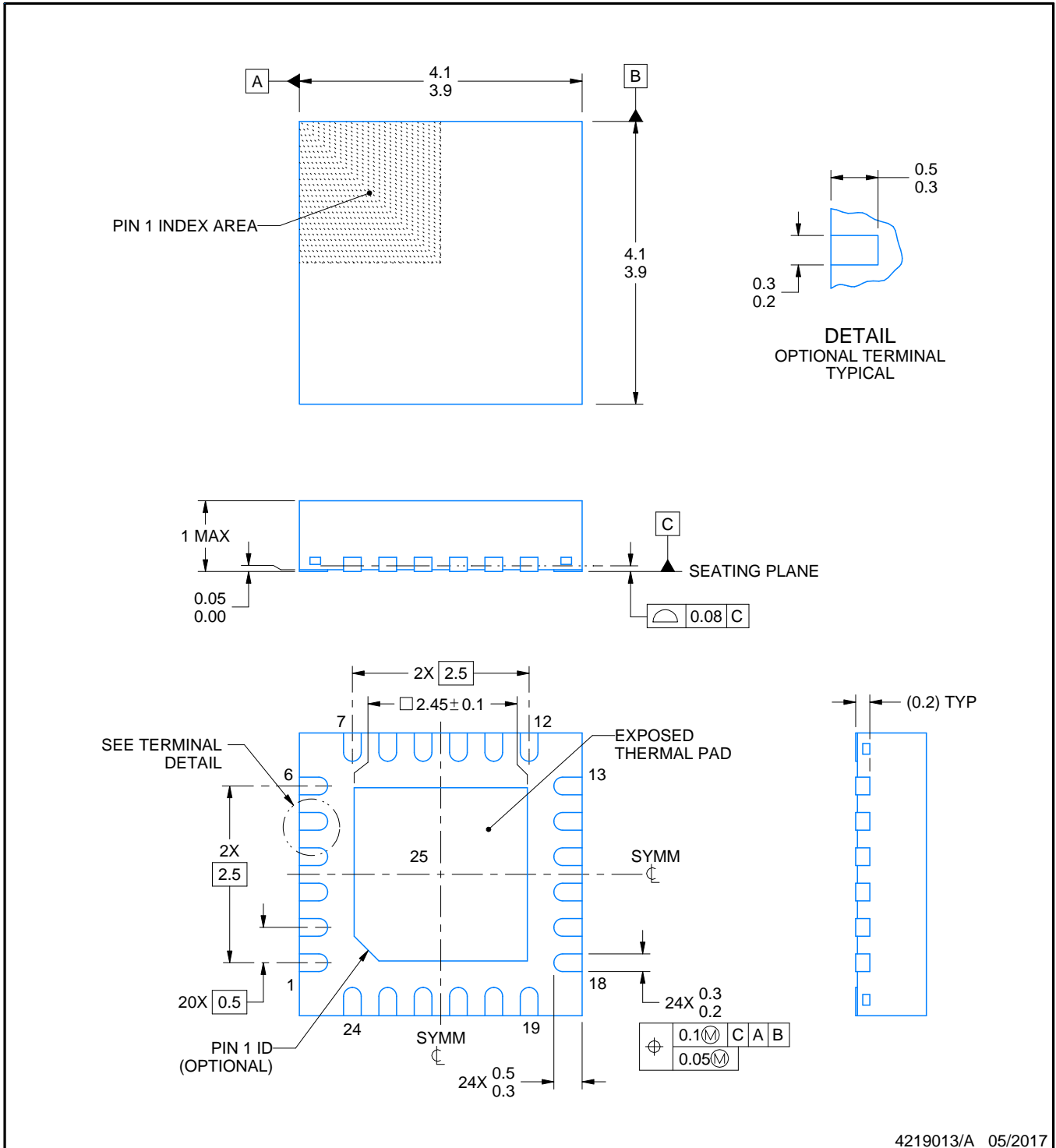
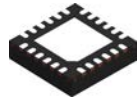

4219013/A 05/2017

NOTES:

1. All linear dimensions are in millimeters. Any dimensions in parenthesis are for reference only. Dimensioning and tolerancing per ASME Y14.5M.
2. This drawing is subject to change without notice.
3. The package thermal pad must be soldered to the printed circuit board for thermal and mechanical performance.

EXAMPLE BOARD LAYOUT

RGE0024B

VQFN - 1 mm max height

PLASTIC QUAD FLATPACK - NO LEAD

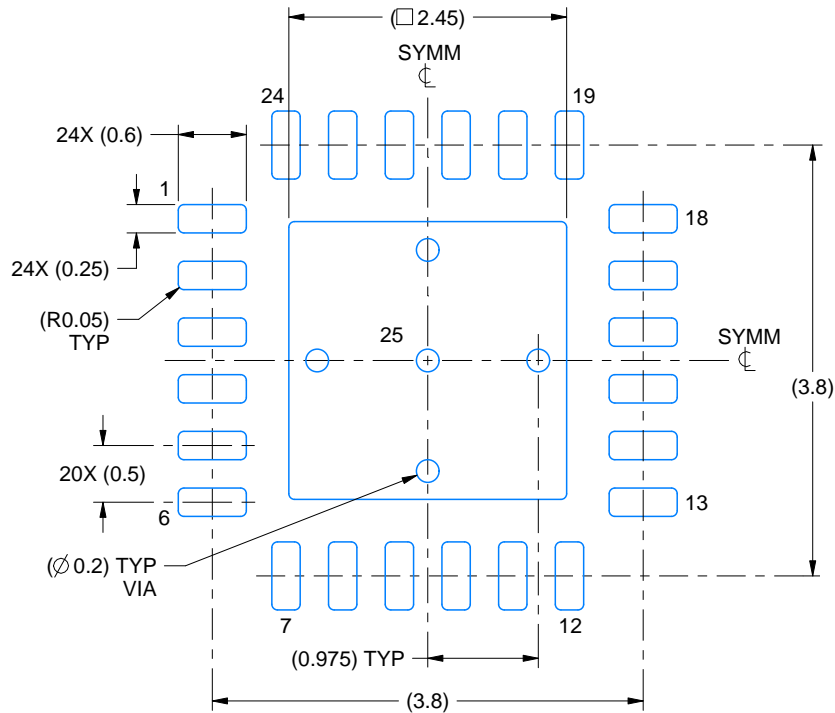

LAND PATTERN EXAMPLE
EXPOSED METAL SHOWN
SCALE:15X

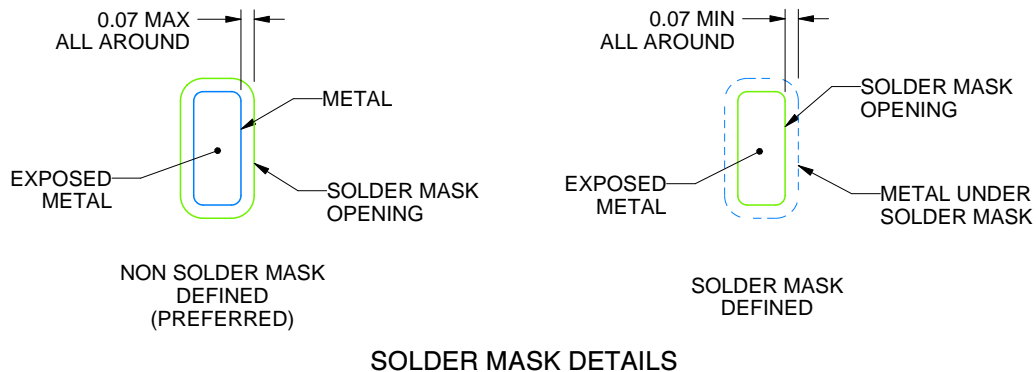

SOLDER MASK DETAILS

4219013/A 05/2017

NOTES: (continued)

- This package is designed to be soldered to a thermal pad on the board. For more information, see Texas Instruments literature number SLUA271 (www.ti.com/lit/slua271).
- Vias are optional depending on application, refer to device data sheet. If any vias are implemented, refer to their locations shown on this view. It is recommended that vias under paste be filled, plugged or tented.

EXAMPLE STENCIL DESIGN

RGE0024B

VQFN - 1 mm max height

PLASTIC QUAD FLATPACK - NO LEAD

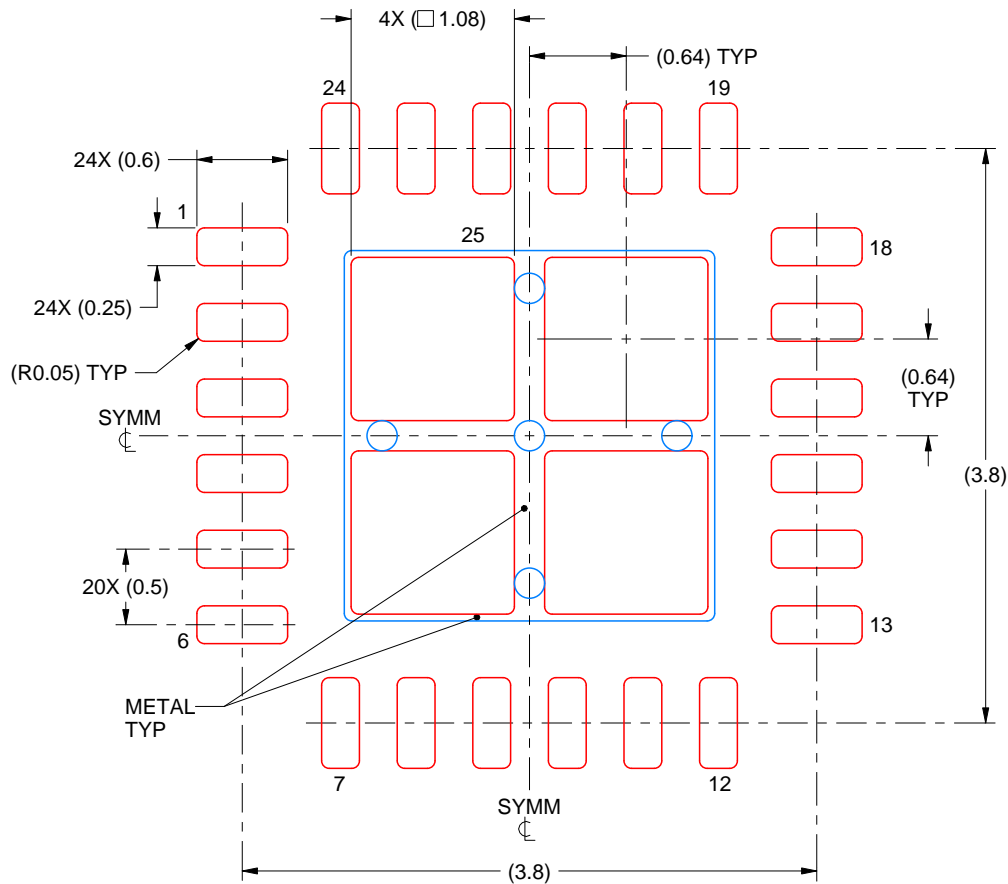

SOLDER PASTE EXAMPLE
 BASED ON 0.125 mm THICK STENCIL

EXPOSED PAD 25
 78% PRINTED SOLDER COVERAGE BY AREA UNDER PACKAGE
 SCALE:20X

4219013/A 05/2017

NOTES: (continued)

6. Laser cutting apertures with trapezoidal walls and rounded corners may offer better paste release. IPC-7525 may have alternate design recommendations.

RTW0024AD



PACKAGE OUTLINE

WQFN - 0.8 mm max height

PLASTIC QUAD FLATPACK - NO LEAD

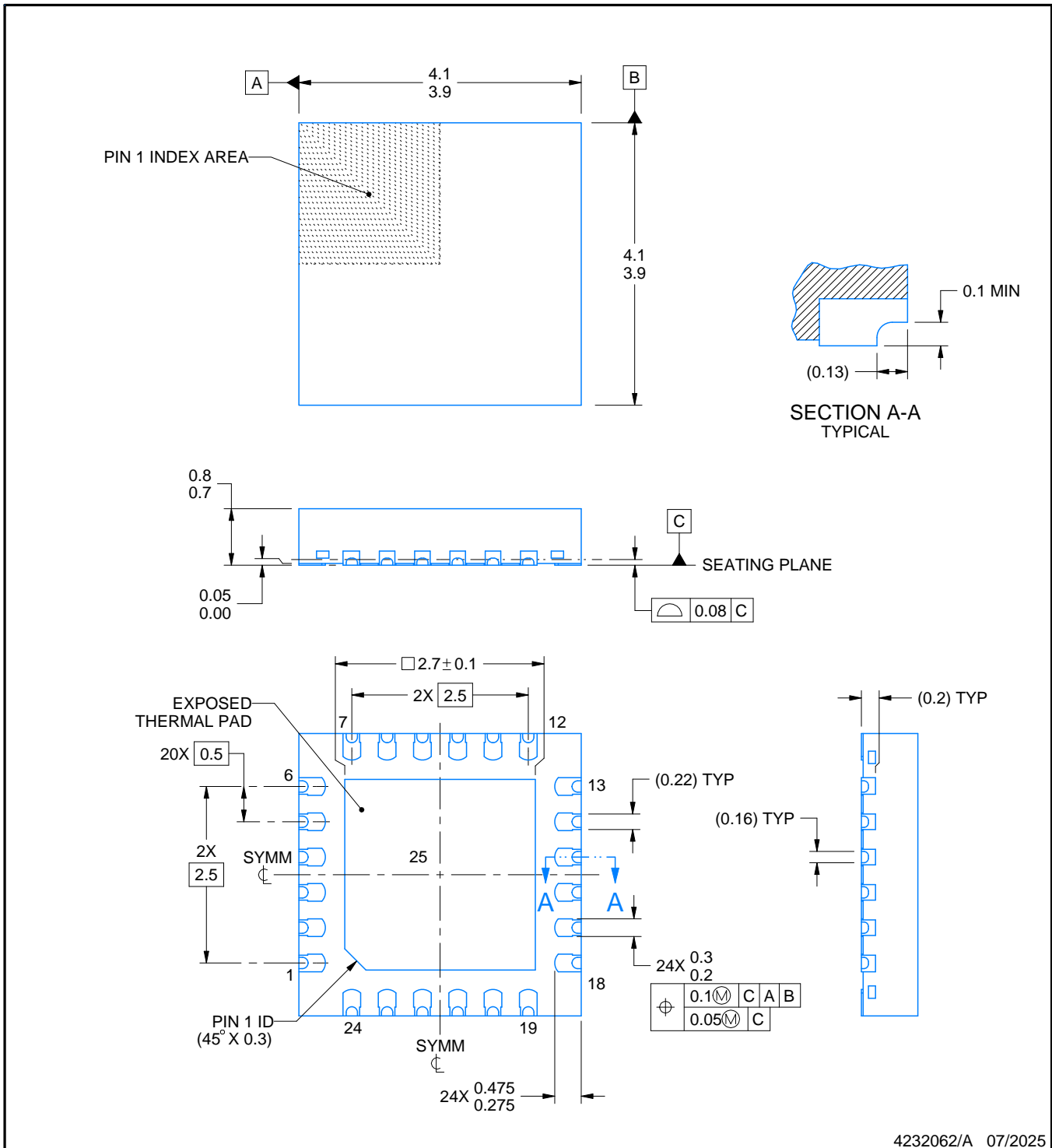

NOTES:

1. All linear dimensions are in millimeters. Any dimensions in parenthesis are for reference only. Dimensioning and tolerancing per ASME Y14.5M.
2. This drawing is subject to change without notice.
3. The package thermal pad must be soldered to the printed circuit board for thermal and mechanical performance.
4. Reference JEDEC registration MO-220.

EXAMPLE BOARD LAYOUT

RTW0024AD

WQFN - 0.8 mm max height

PLASTIC QUAD FLATPACK - NO LEAD

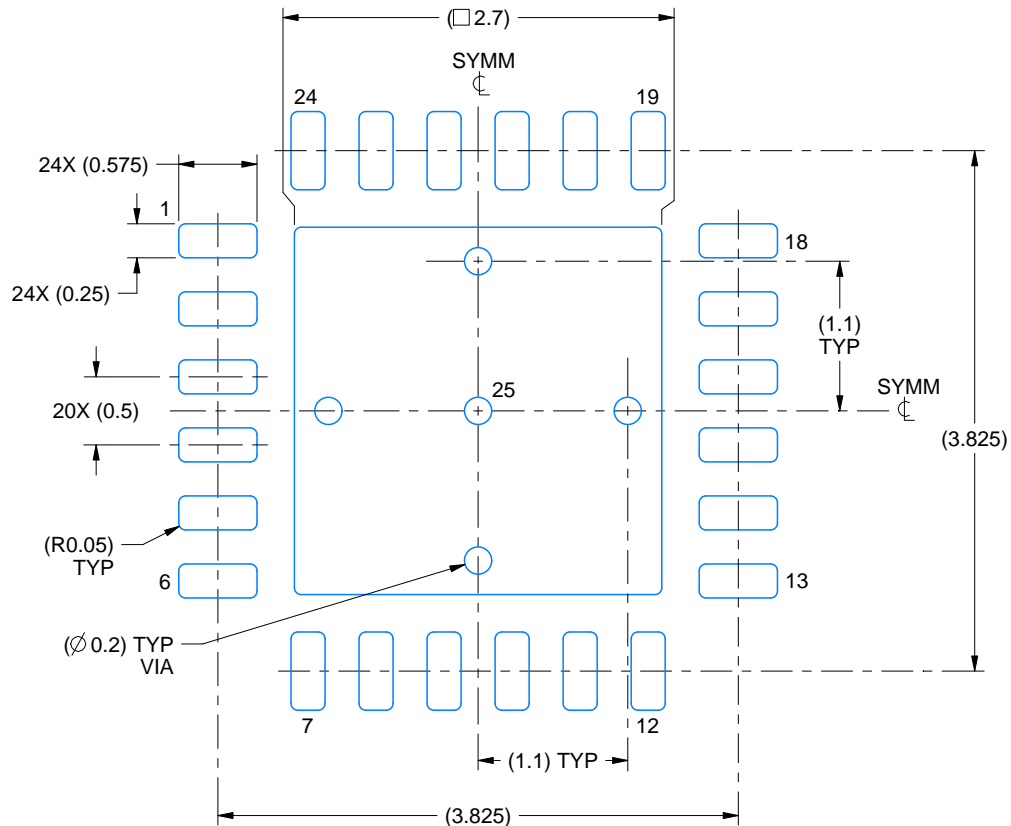

LAND PATTERN EXAMPLE
EXPOSED METAL SHOWN
SCALE:18X

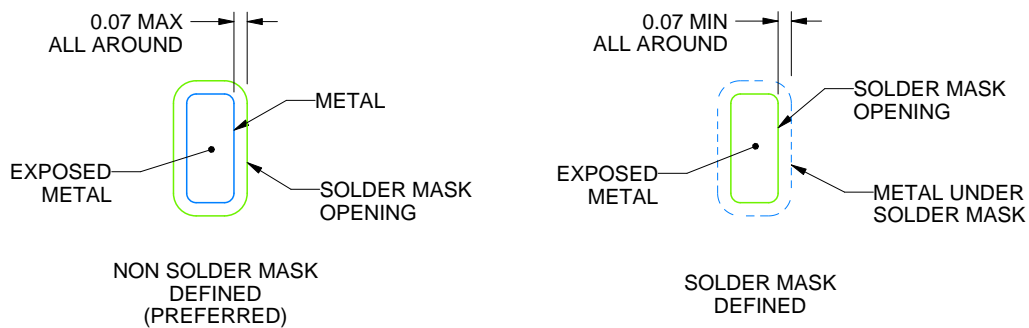

SOLDER MASK DETAILS

4232062/A 07/2025

NOTES: (continued)

5. This package is designed to be soldered to a thermal pad on the board. For more information, see Texas Instruments literature number SLUA271 (www.ti.com/lit/sluea271).
6. Vias are optional depending on application, refer to device data sheet. If any vias are implemented, refer to their locations shown on this view. It is recommended that vias under paste be filled, plugged or tented.

EXAMPLE STENCIL DESIGN

RTW0024AD

WQFN - 0.8 mm max height

PLASTIC QUAD FLATPACK - NO LEAD

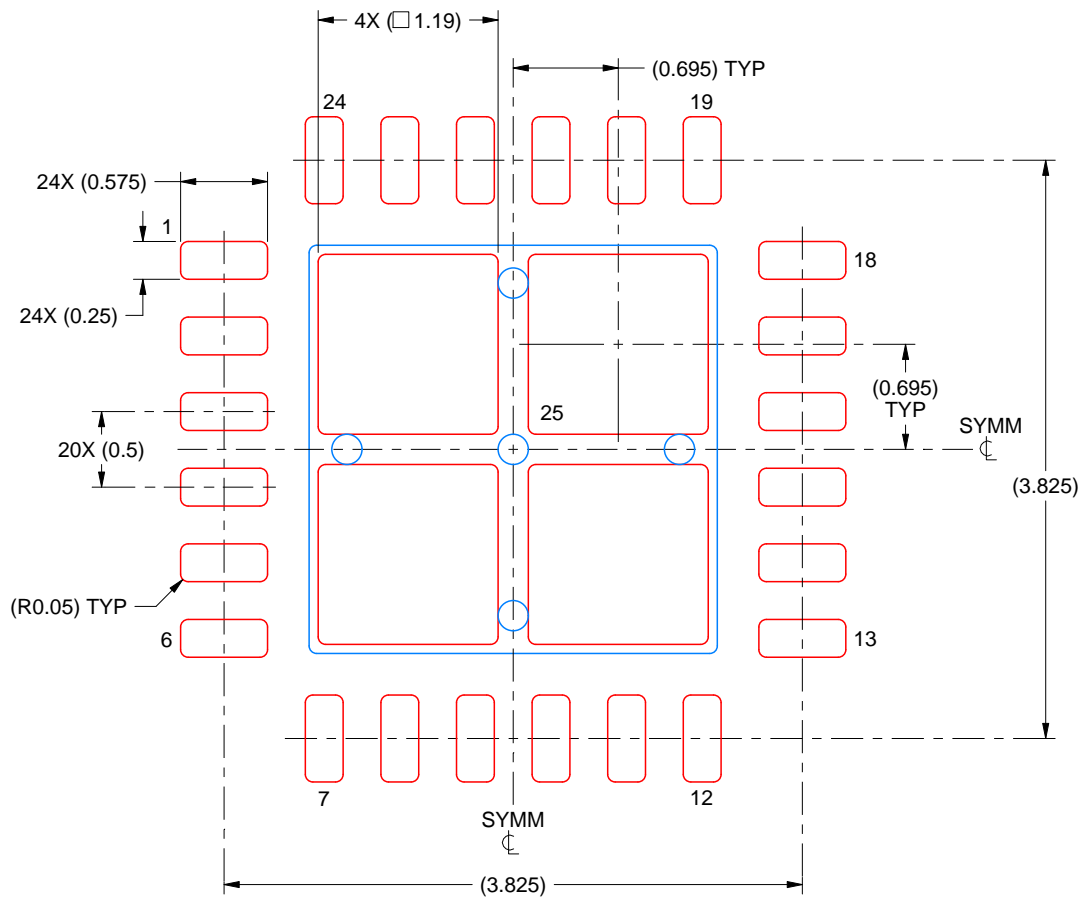

SOLDER PASTE EXAMPLE
BASED ON 0.125 mm THICK STENCIL

EXPOSED PAD 25
78% PRINTED SOLDER COVERAGE BY AREA UNDER PACKAGE
SCALE:20X

4232062/A 07/2025

NOTES: (continued)

7. Laser cutting apertures with trapezoidal walls and rounded corners may offer better paste release. IPC-7525 may have alternate design recommendations.

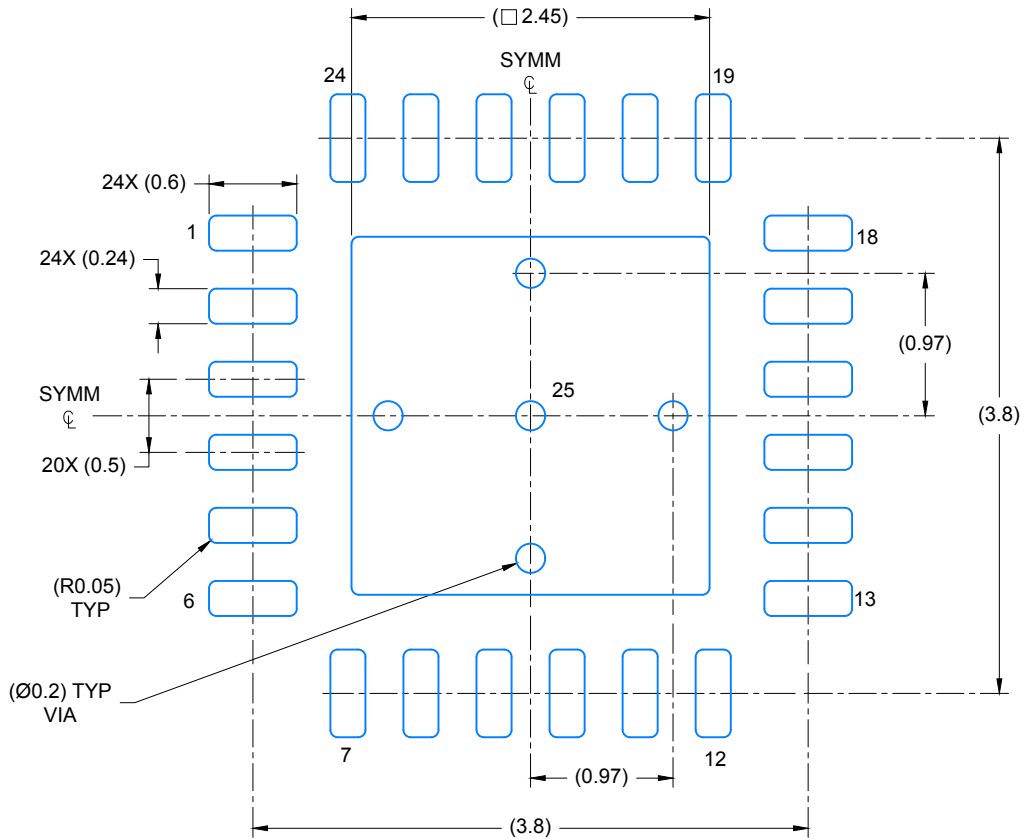

LAND PATTERN EXAMPLE
SCALE: 20X

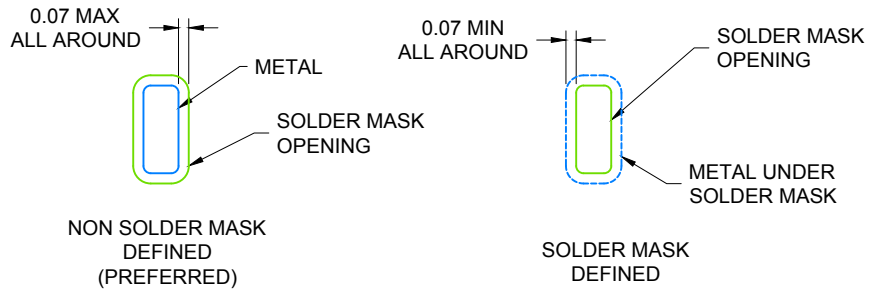

SOLDER MASK DETAILS

4219135/B 11/2016

NOTES: (continued)

- For more information, see Texas Instruments literature number SLUA271 (www.ti.com/lit/sluea271).

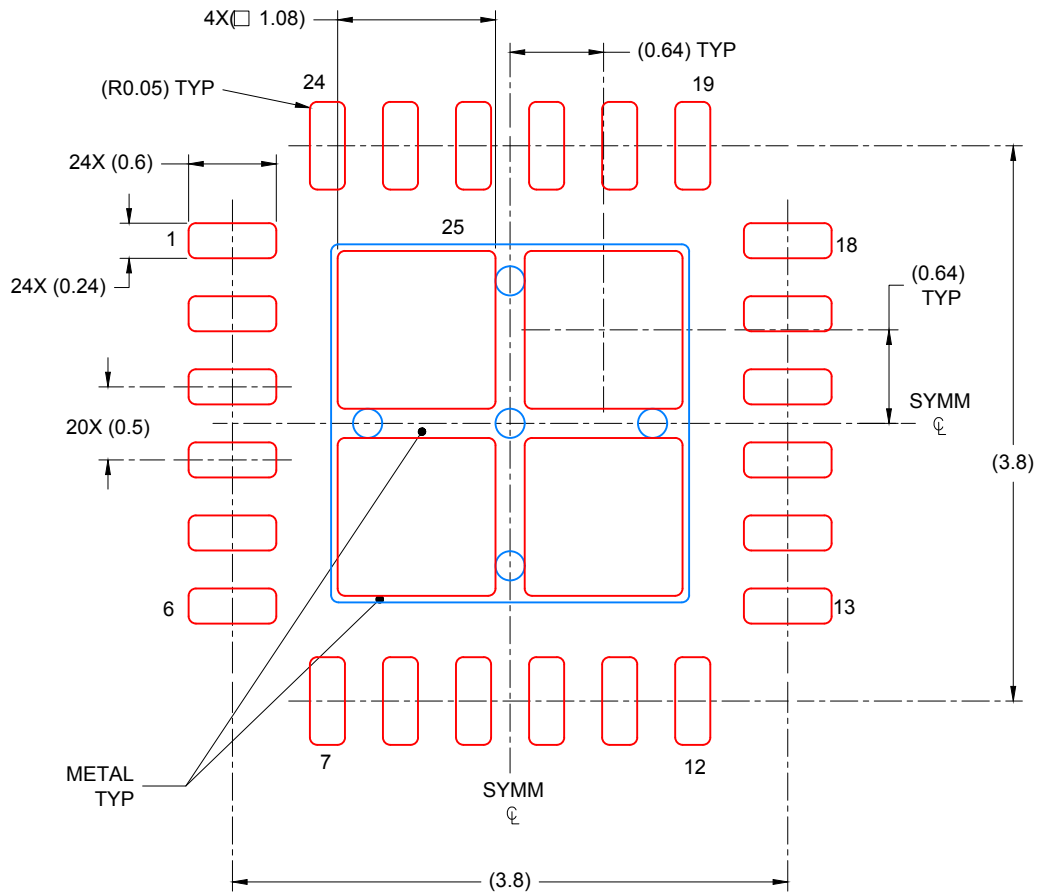

SOLDER PASTE EXAMPLE
 BASED ON 0.125 mm THICK STENCIL

EXPOSED PAD 25:
 78% PRINTED COVERAGE BY AREA UNDER PACKAGE
 SCALE: 20X

4219135/B 11/2016

NOTES: (continued)

4. Laser cutting apertures with trapezoidal walls and rounded corners may offer better paste release. IPC-7525 may have alternate design recommendations.

GENERIC PACKAGE VIEW

RTW 24

WQFN - 0.8 mm max height

4 x 4, 0.5 mm pitch

PLASTIC QUAD FLATPACK - NO LEAD

This image is a representation of the package family, actual package may vary.
Refer to the product data sheet for package details.

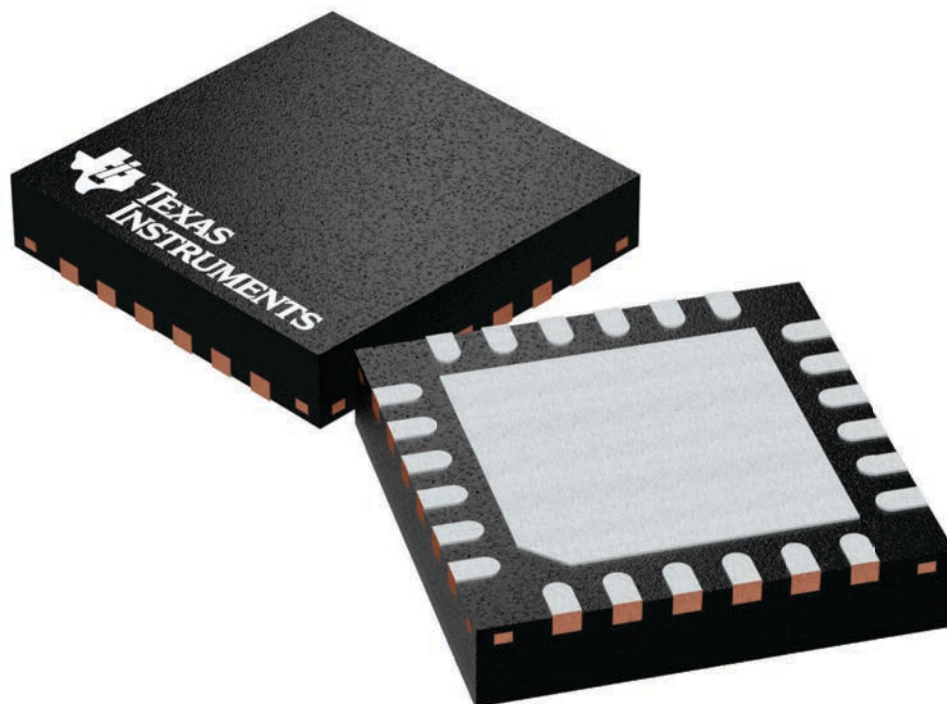

4224801/A

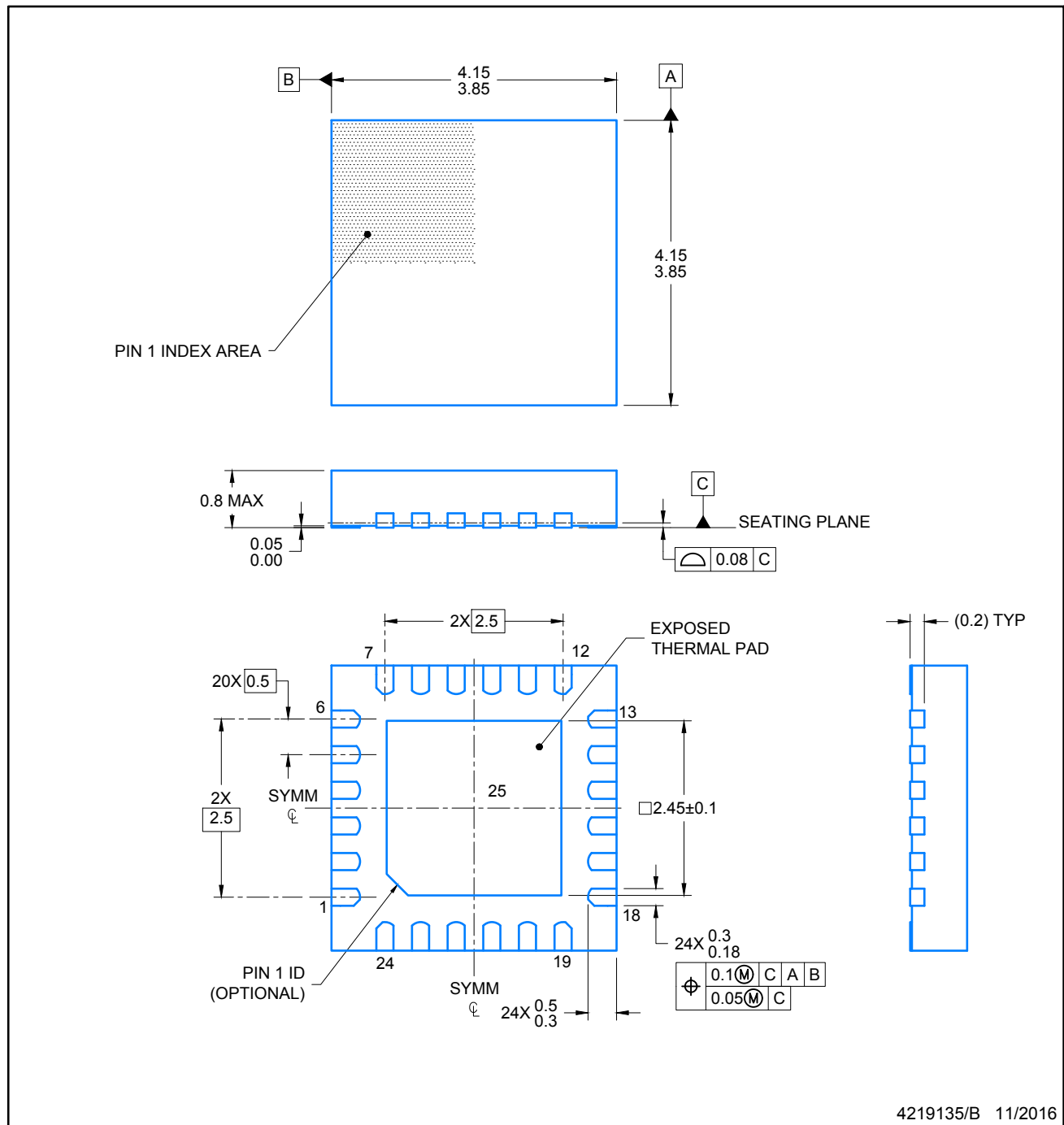

4219135/B 11/2016

NOTES:

1. All linear dimensions are in millimeters. Any dimensions in parenthesis are for reference only. Dimensioning and tolerancing per ASME Y14.5M.
2. This drawing is subject to change without notice.

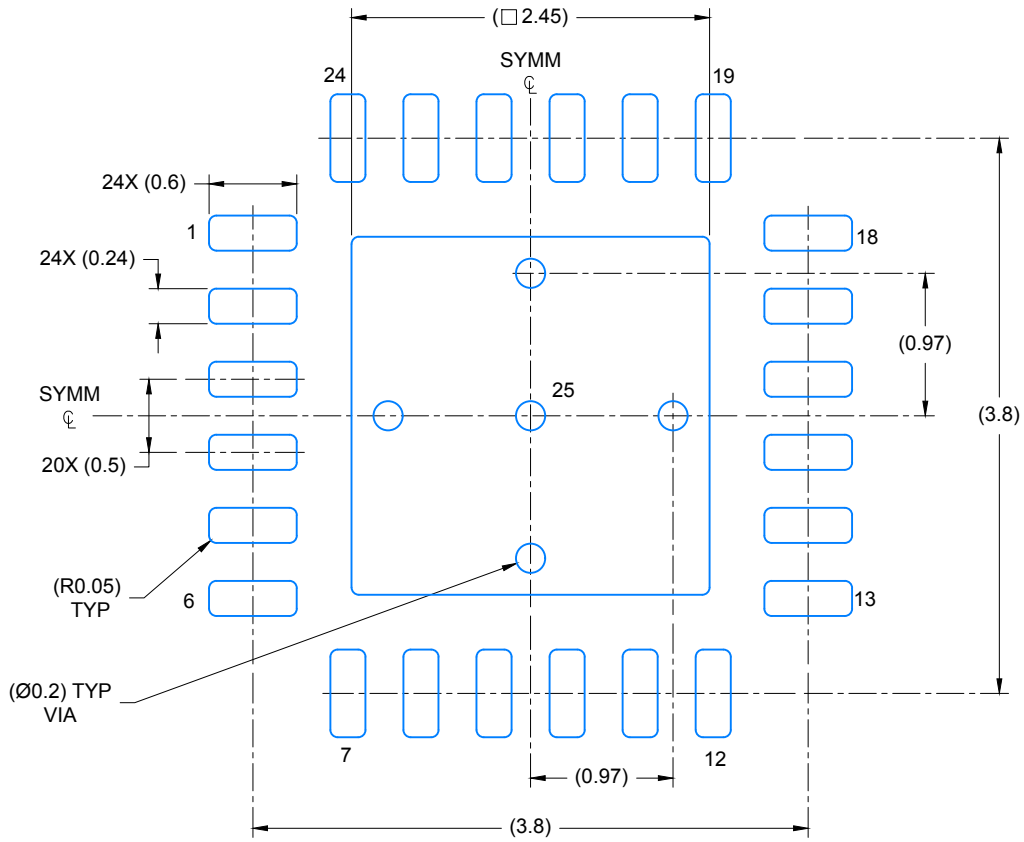

LAND PATTERN EXAMPLE
SCALE: 20X

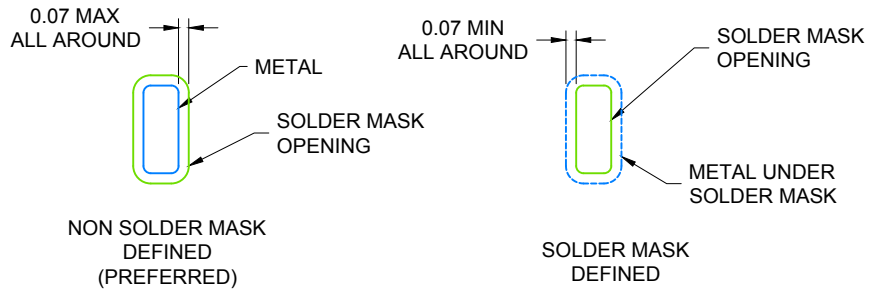

SOLDER MASK DETAILS

4219135/B 11/2016

NOTES: (continued)

- For more information, see Texas Instruments literature number SLUA271 (www.ti.com/lit/sluea271).

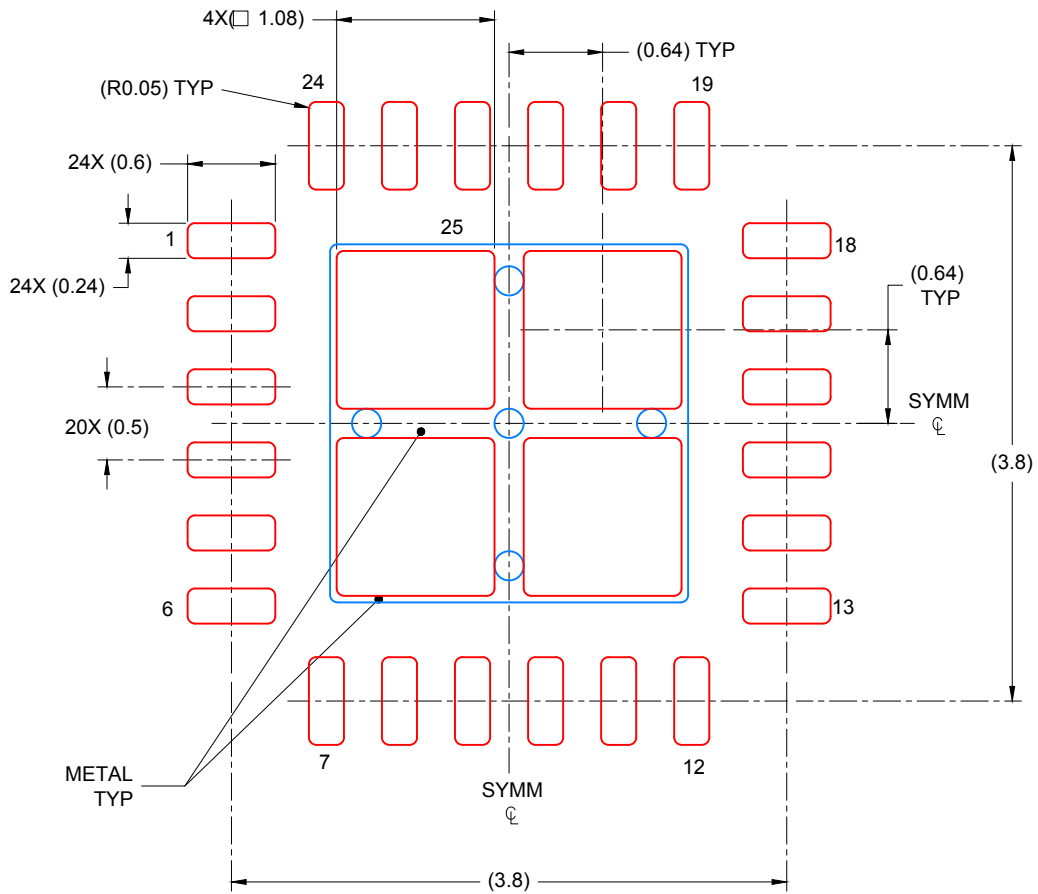

SOLDER PASTE EXAMPLE
 BASED ON 0.125 mm THICK STENCIL

EXPOSED PAD 25:
 78% PRINTED COVERAGE BY AREA UNDER PACKAGE
 SCALE: 20X

4219135/B 11/2016

NOTES: (continued)

4. Laser cutting apertures with trapezoidal walls and rounded corners may offer better paste release. IPC-7525 may have alternate design recommendations.

DB (R-PDSO-G**)

PLASTIC SMALL-OUTLINE

28 PINS SHOWN

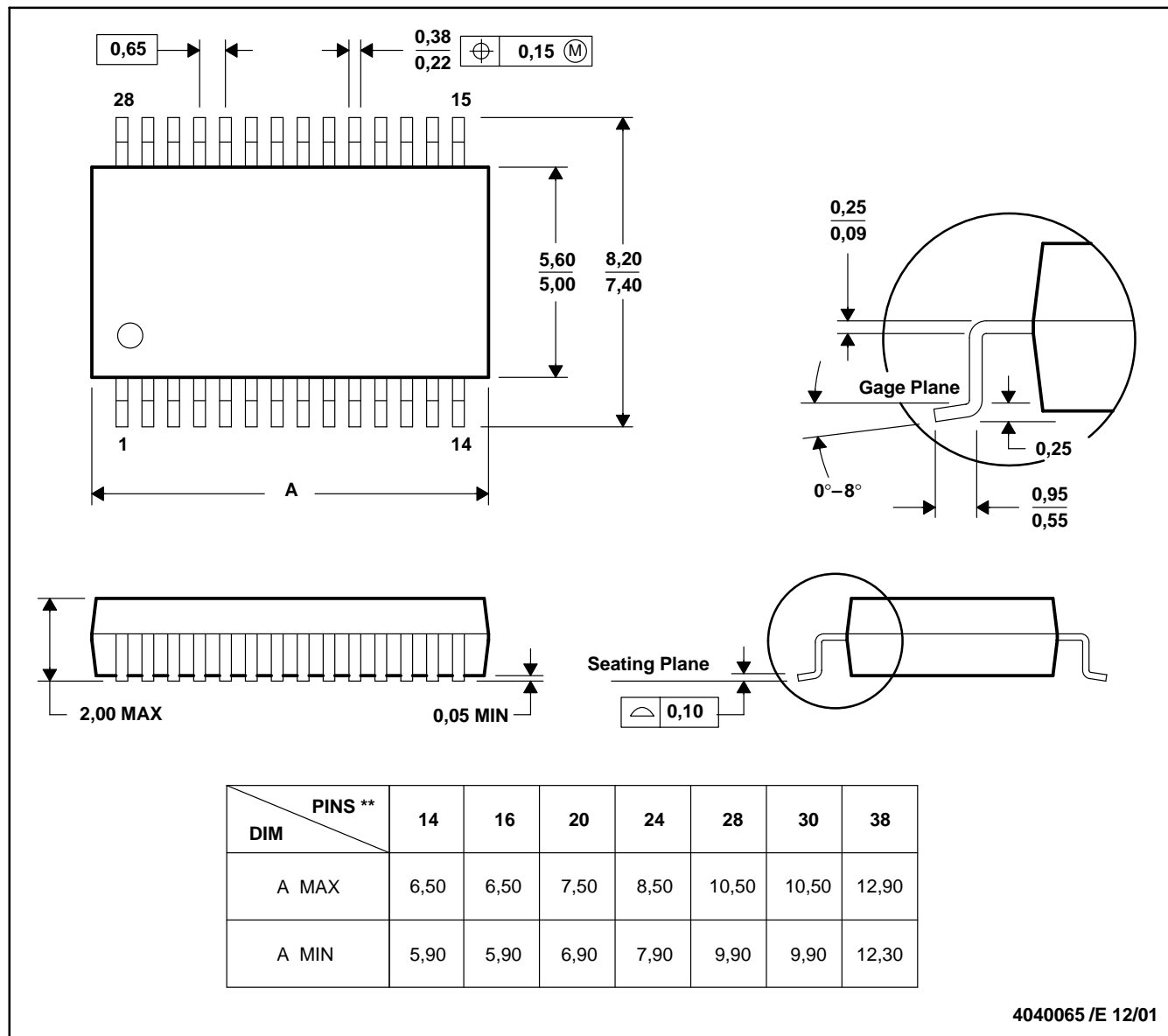

- NOTES: A. All linear dimensions are in millimeters.
 B. This drawing is subject to change without notice.
 C. Body dimensions do not include mold flash or protrusion not to exceed 0,15.
 D. Falls within JEDEC MO-150

4040065 /E 12/01

PW0024A

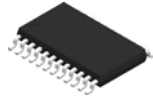

PACKAGE OUTLINE
TSSOP - 1.2 mm max height

SMALL OUTLINE PACKAGE

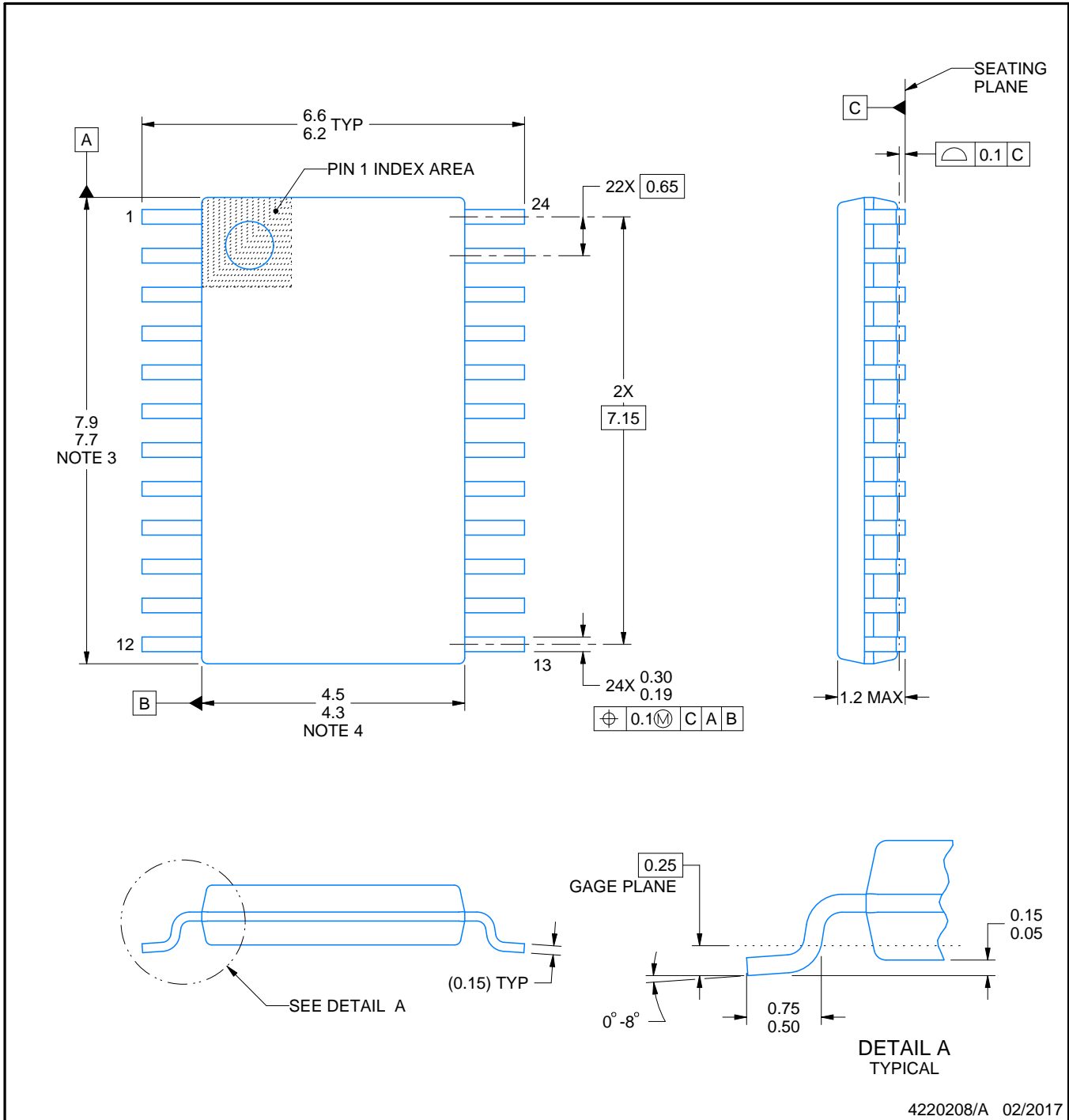

NOTES:

1. All linear dimensions are in millimeters. Any dimensions in parenthesis are for reference only. Dimensioning and tolerancing per ASME Y14.5M.
2. This drawing is subject to change without notice.
3. This dimension does not include mold flash, protrusions, or gate burrs. Mold flash, protrusions, or gate burrs shall not exceed 0.15 mm per side.
4. This dimension does not include interlead flash. Interlead flash shall not exceed 0.25 mm per side.
5. Reference JEDEC registration MO-153.

EXAMPLE BOARD LAYOUT

PW0024A

TSSOP - 1.2 mm max height

SMALL OUTLINE PACKAGE

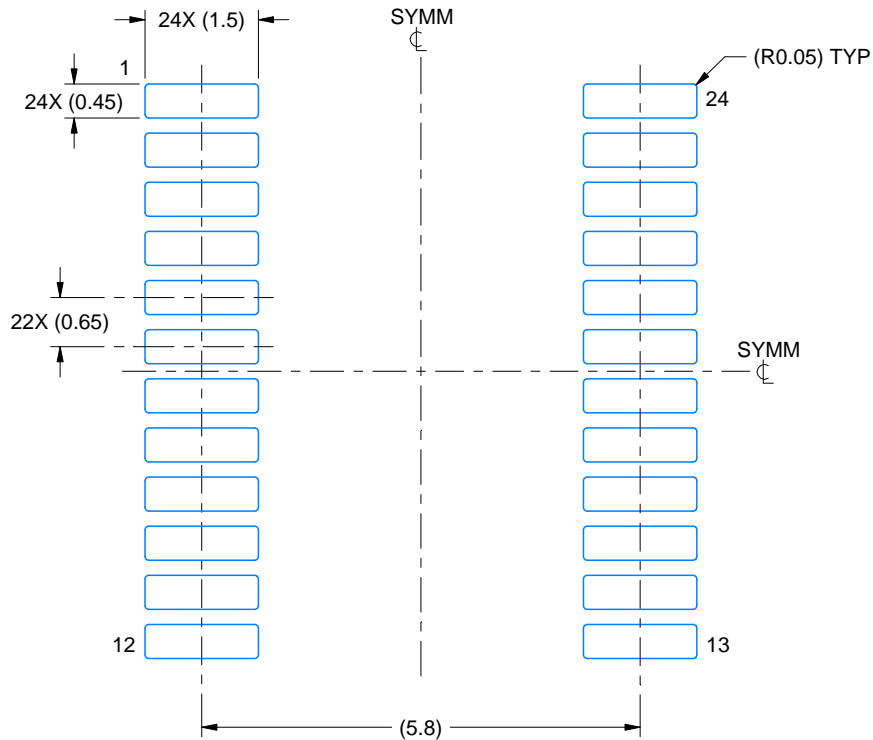

LAND PATTERN EXAMPLE
EXPOSED METAL SHOWN
SCALE: 10X

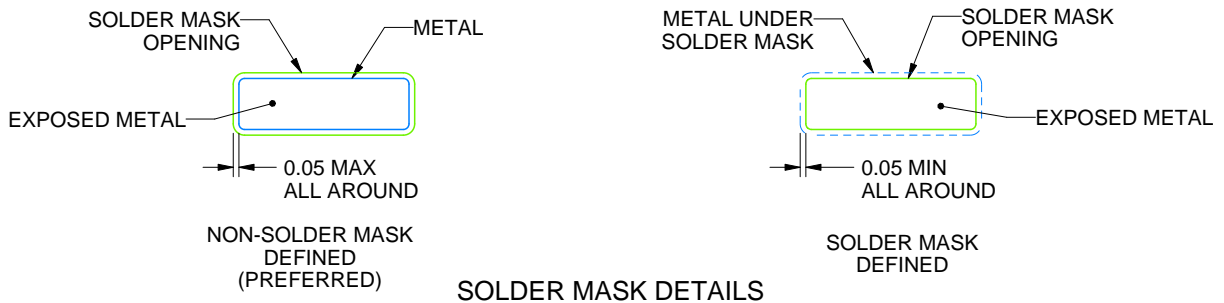

SOLDER MASK DETAILS

4220208/A 02/2017

NOTES: (continued)

- 6. Publication IPC-7351 may have alternate designs.
- 7. Solder mask tolerances between and around signal pads can vary based on board fabrication site.

EXAMPLE STENCIL DESIGN

PW0024A

TSSOP - 1.2 mm max height

SMALL OUTLINE PACKAGE

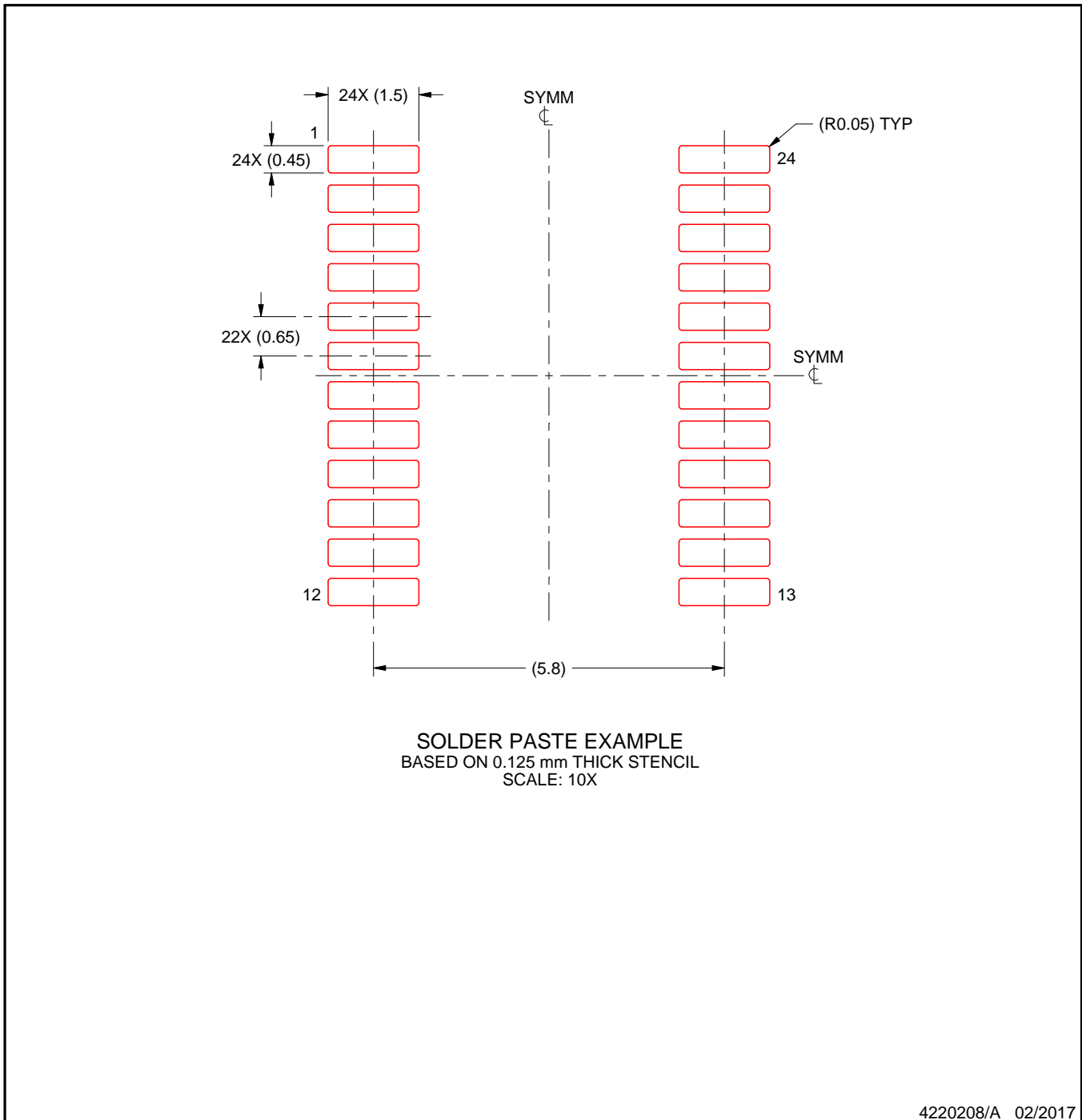

NOTES: (continued)

8. Laser cutting apertures with trapezoidal walls and rounded corners may offer better paste release. IPC-7525 may have alternate design recommendations.
9. Board assembly site may have different recommendations for stencil design.

重要通知和免责声明

TI“按原样”提供技术和可靠性数据（包括数据表）、设计资源（包括参考设计）、应用或其他设计建议、网络工具、安全信息和其他资源，不保证没有瑕疵且不做任何明示或暗示的担保，包括但不限于对适销性、某特定用途方面的适用性或不侵犯任何第三方知识产权的暗示担保。

这些资源可供使用 TI 产品进行设计的熟练开发人员使用。您将自行承担以下全部责任：(1) 针对您的应用选择合适的 TI 产品，(2) 设计、验证并测试您的应用，(3) 确保您的应用满足相应标准以及任何其他功能安全、信息安全、监管或其他要求。

这些资源如有变更，恕不另行通知。TI 授权您仅可将这些资源用于研发本资源所述的 TI 产品的相关应用。严禁以其他方式对这些资源进行复制或展示。您无权使用任何其他 TI 知识产权或任何第三方知识产权。您应全额赔偿因在这些资源的使用中对 TI 及其代表造成的任何索赔、损害、成本、损失和债务，TI 对此概不负责。

TI 提供的产品受 [TI 的销售条款](#) 或 [ti.com](#) 上其他适用条款/TI 产品随附的其他适用条款的约束。TI 提供这些资源并不会扩展或以其他方式更改 TI 针对 TI 产品发布的适用的担保或担保免责声明。

TI 反对并拒绝您可能提出的任何其他或不同的条款。

邮寄地址：Texas Instruments, Post Office Box 655303, Dallas, Texas 75265
版权所有 © 2025，德州仪器 (TI) 公司